



901 INDUSTRIAL BLVD.
NAPLES, FL 34104

COMPLIES WITH
NFPA-13 2016*

loosseismicbracing.com
800.321.LOOS (5667)

LOOS & CO. INC.

CABLEWARE® DIVISION

• SEISMIC BRACING CABLE •

SEISMIC DESIGN GUIDE CABLE BRACING SYSTEM



* Loos & Co. Seismic Cable Bracing Products is not affiliated with or endorsed by NFPA.

SECTION 1- GENERAL INFORMATION

1	Preface
1	General Introduction
2	Application
2	Reprint Permission Restrictions
2	Seismic Calculator
2	Video How-Tos
3-8	Hand Tool Information
9	Eye and Lap Splice Instructions
10	Description of Cable Kit Part Numbers

SECTION 2 - PRODUCTS

11-15	Bulk Cable Spools
16	Zinc-Plated Oval Sleeves
17-23	Seismic Anchoring Fitting (SAF) Series
24-28	Seismic Attachment Fitting Retrofit (SAFR) Series
29-35	Seismic Attachment Fitting 2 (SAF2) Series
36-40	Seismic Attachment Fitting Retrofit 2 (SAFR2) Series
41-48	Low-Pry Fitting (LPF) Series
49-57	Cable Kits

SECTION 3 - INSTALLATION INSTRUCTIONS

59	Lateral Bracing Installation
60	Longitudinal Bracing Installation
61	4-Way Bracing Installation
62	Splicing Info
63-71	Installation - Angles A, B, and C
72-79	Installation - Angles D, E, and F
80-87	Installation - Angles G, H, and I
88	Bar Joist Loop Installation
89	Riser Bracing - Angle Roof
90	Riser Bracing - Flat Roof
91	Riser Bracing- Wall Installation
92	Clevis Pin Installation
93	Pipe Hanger Installation

SECTION 4 - APPENDIX

95	Applied Load
96-101	Misc. Loads
102	CPVC Pipe Weights
103	Schedule 7 Pipe Weights
104	Schedule 10 Pipe Weights
105	Schedule 40 Pipe Weights
106	Concrete Anchor Orientations & Respective Prying Factor Formulas
107	Seismic Coefficient Table

PREFACE

Whether it's drawn stainless steel wire, aircraft cable, seismic cable assemblies, fittings, or tools, **Loos & Co., Inc.** has what you are looking for. Our technical expertise, developed over the last sixty years, has enabled us to provide essential materials to various industries, including aerospace, automotive, medical, and industrial markets. We take pride in our technical abilities, modern manufacturing equipment and rigid quality control standards to guarantee on-time delivery to the most critical specifications.

Loos & Co., Inc. has earned its reputation by continuously meeting and exceeding the increasingly stringent safety requirements of the aerospace industry. We have taken that level of safety, combined with 60+ years of knowledge and expertise and applied this methodology to our Seismic Bracing Cable system.

Loos & Co., Inc. has been providing seismic bracing cable and hardware since 1993. What we have seen over the years is an evolution from what was once confusion and misconception to an industry that has gone above and beyond to embrace nationally accepted codes and standards.

Loos & Co., Inc. has taken this position to the next level by obtaining all of the certifications required to make our Seismic Bracing Cable the most cost-effective. **Loos & Co., Inc.** is certified and listed by 3rd party independent test labs.

Loos & Co., Inc. certifications include:

- Third party listed (UL, Intertek, and ICC-ES) for use in complying with NFPA 13 for fire sprinkler systems.
- Third party listed (ICC-ES) for use in complying with the International Building Code (IBC).
- Third party tested/listed to verify that cable assemblies, including fittings, maintain the nominal breaking strength per ASCE 19, as required by IBC, ASCE 7, and NFPA-13.
- Have swaged end fittings as required by the 2018 IBC per ASCE 19-16, which does not permit wedge or clip-type fittings.
- Certify the minimum breaking strength of the sway bracing assemblies.
- Comply with NFPA-13, ASCE 19, the IBC and ASCE 7.
- Listed by the FBC for system compatibility with Lubrizol CPVC pipe. Visit fbcsystemcompatible.com for additional information. FBC™ is a trademark of Lubrizol Corporation. Made with Temp Rite® Technology.
- Listed as approved products in Spears CPVC Compatibility List

In this guide, you will find all of the specifications, descriptions and applicable drawings for all of the Seismic products **Loos & Co., Inc.** offers. This will allow the user to identify and specify the proper components to satisfy the code requirements of the local authority having jurisdiction (AHJ).

Thank you for your interest in our Seismic Cable Bracing System manufactured by **Loos & Co., Inc.**

GENERAL INTRODUCTION

Loos & Co.'s Seismic Design Guide will assist you in the design and installation of our Seismic Cable Bracing System. All of the materials and products presented have been designed and tested to exceed the requirements set forth in NFPA-13. In fact, the provisions of NFPA-13 directly provide for the use of tension only bracing where listed for this service and where installed in accordance with their listing limitations, including installation instructions. Ref. 9.3.5.4.2* in NFPA-13 Standard for the Installation of Sprinkler Systems **Loos & Co., Inc.** has been providing Seismic Cable Bracing since 1993 in structures located all over the world, both for new and retro-fit buildings.



CABLEWARE® DIVISION
SEISMIC BRACING CABLE

APPLICATION OF THIS PUBLICATION

In this publication you will find information regarding proper installation techniques and guidelines applicable to **Loos & Co., Inc.** Seismic Cable Bracing System for meeting existing codes and standards. It has been compiled using proven engineering ethics and principles. Final accountability for approving specific designs, code interpretations, and/or installations rests with the engineer responsible for the specific design and/or the agency or authority having jurisdiction (AHJ). **Loos & Co., Inc.** and/or contributors to this publication assume no liability for the specific installation of its products or the design, application, approval, or interpretation of the requirements or guidelines contained in this publication. Users of this publication are encouraged to confer with certified design Engineers (P.E.) as well as all applicable Federal, State, and local regulations or requirements for specific installations.

REPRINT PERMISSION RESTRICTIONS

Permission is granted to government and private sector users of this publication to reproduce unaltered conceptual drawings from this publication for their use relating to the specific design, specification, installation, or approval of **Loos & Co., Inc.'s** Seismic Cable Bracing. Reproduction for the purpose of its sale is prohibited. Any other use or reproduction of this publication shall be first approved in writing by **Loos & Co., Inc.** Liability for the specific application of such information, including errors or omissions in reproduction is solely the responsibility of the party reproducing such material.

ENGINEERS' TOOLS - SEISMIC CALCULATOR

This Design Guide can be used in conjunction with our Engineers' Tools Seismic Design Calculator which is accessible for free from our website (www.loosseismicbracing.com). The Seismic Design Calculator allows the user to enter all the details for fire sprinkler installations from the building blueprints then print out the completed NFPA-13 form with all of the calculations complete and ready to submit to your local AHJ. As an added bonus, our Seismic Design Calculator software will also generate a Bill of Material based on input from the user. This Bill of Materials can then be utilized for quoting purposes.

VIDEO HOW-TOS

Visit our website (www.loosseismicbracing.com) for how-to installation videos in both English and Spanish. Look for the QR codes on many of Loos Seismic Bracing products for easy access.

Loos & Co., Inc. Cableware Division - Seismic Cable Bracing

901 Industrial Boulevard
Naples, Florida 34104
(800) 321-LOOS (5667)
www.loosseismicbracing.com

#0-3-SBHS HAND SWAGER

The preferred tool for swaging gold cable (#GO3-CBL).

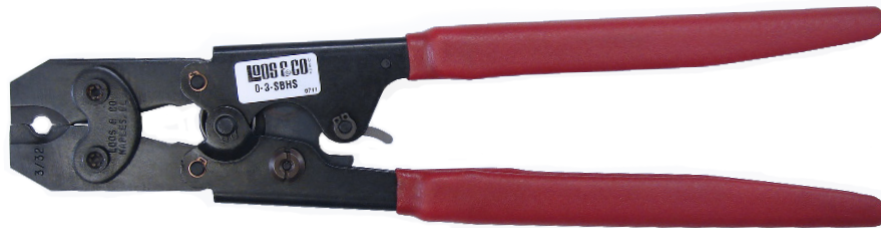

A well-made, economical hand swaging tool for #GO3 cable sleeves, our most popular cable size. Loos offers the correct tools to use in swaging zinc-plated oval sleeves. Using the correct tool and following proper swaging instructions will ensure proper cable connections that actually exceed the breaking strength of the cable.

OPERATION INSTRUCTIONS

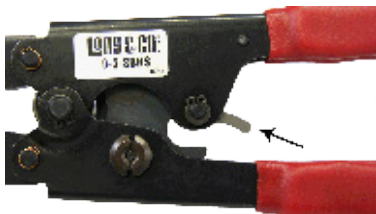

Figure 1



Figure 2



Figure 3

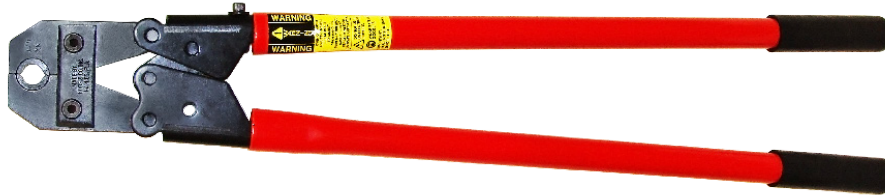

Figure 4

1. To open tool squeeze handles hard or push release lever (Figure 1) forward while squeezing handles to relieve tension.
2. Place the sleeve on the cable and make a loop around the item to which you are securing the cable.
3. Next, insert cable end through the sleeve and at least 1/8" or more beyond (Figure 2).
4. While holding sleeve in place, swage one compression. Move over and swage (second compression). Two compressions are required. The tool won't release until compression is complete.
5. Check sleeve for proper after swage diameter with gauge provided (Figure 4). The clamping action of the ratchet allows the sleeve to be held by the tool before completing the swage. This allows for the user to adjust the position of the sleeve on the cable.
6. After swaging, excess cable may be cut off with Felco® C7 cutters (see page 6).

#0-1/4 HAND SWAGER

The preferred tool for swaging black cable (#BL8-CBL).



A well-made, economical handswaging tool for swaging #BL8 (BLACK) cable sleeves. Loos offers the correct tools to use in swaging our zinc-plated oval sleeves.

Using the correct tool and following proper swaging instructions will ensure proper cable connections that actually exceed the breaking strength of the cable.

OPERATION INSTRUCTIONS



Cable Size	Number of Compressions
#BL8 (Black)	3

1. Place sleeve to be compressed in groove in swaging tool.
2. A length of cable (minimum) equal to the cable diameter should extend beyond the length of sleeve to achieve maximum holding.
3. Keep jaws of swaging tool at right angles to the sleeve to be compressed, making sure the sleeve is aligned in the jaw grooves.
4. Close tool completely. Tool handles should snap shut indicating complete closure.
5. Swage for proper number of compressions.
6. Use the swaging gauge provided with tool to check proper after swage diameter of sleeve. Compressed sleeve should slide freely into corresponding size in gauge.

#3-346SB HAND SWAGER

For #GO3, #OR4, and #GR6 cable



Each **Loos & Co., Inc.** #3-346SB swaging tool is designed to work with #GO3, #OR4, and #GR6 zinc-plated copper oval sleeves. For use only on **Loos & Co., Inc.** Seismic Cable Bracing sizes #GO3, #OR4, and #GR6. Using the correct tool and following proper swaging instructions will ensure proper cable connections that actually exceed the breaking strength of the cable. You will not obtain proper performance or meet UL standards if you do not use the proper **Loos & Co., Inc.** swaging tool and sleeve combination.

OPERATION INSTRUCTIONS



Figure 1

Cable Size	Number of Compressions
#GO3 (Gold)	2
#OR4 (Orange)	2
#GR6 (Green)	3

Figure 2



Figure 3

1. Place sleeve to be compressed in proper size groove in swaging tool by matching cable color to colored dot next to groove in tool (Figure 1).
2. A minimum length of cable equal to the cable diameter should extend beyond the length of sleeve to achieve maximum holding.
3. Keep jaws of swaging tool at right angles to the sleeve to be compressed, making sure the sleeve is aligned in the jaw grooves.
4. Close tool completely. Tool handles should snap shut indicating complete closure.
5. Swage for proper number of compressions (Figure 2).
6. Use the swaging gauge provided with the tool to check proper after-swage diameter of sleeve. Compressed sleeve should slide freely into corresponding size and color slot in gauge (Figure 3).

SL-7ND346-SB BATTERY-POWERED SWAGER

For #GO3, #OR4, and #GR6 cable



A well-made and powerful, state-of-the-art battery-powered swaging tool. This newest technology eliminates the need to swage Loos zinc-plated oval sleeves by hand. This is especially helpful when a large number of brace connections are required for the job. Kit comes complete with two long-lasting, fast charge lithium-ion batteries, one-hour quick charger, and handy carrying case so you can be sure to have strong portable power at all times.

OPERATION INSTRUCTIONS



Cable Size	Number of Compressions
#GO3 (Gold)	2
#OR4 (Orange)	2
#GR6 (Green)	3



1. Place sleeve to be compressed in proper size groove in swaging tool by matching cable color to colored dot next to groove in tool.
2. Press on the forward trigger to crimp the sleeve onto the cable. An audible click advises when the swage is completed.
3. Open the jaws of the tool by pressing the retract trigger. You may now start another crimp cycle of the tool. Refer to the number of compressions table (Figure). For lap splices, two sleeves should be used.



BATTERY CARTRIDGE



BATTERY CHARGER



CARRYING CASE

SL-7NDK-SB BATTERY-POWERED SWAGER

For #GO3, #OR4, #GR6 and #BL8 cable



A very well-made and powerful, state-of-the-art, battery-powered swaging tool that has replaceable swaging dies. This allows the user to have one reliable tool that will swage all sizes of Loos' zinc-plated oval sleeves.

OPERATION INSTRUCTIONS

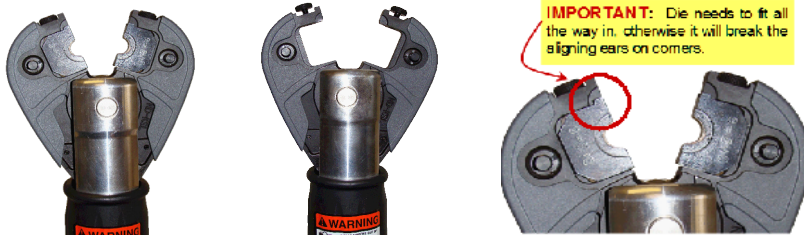
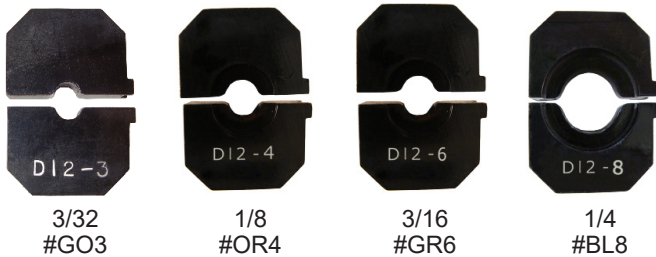

Cable Size	Number of Compressions
#GO3 (Gold)	1
#OR4 (Orange)	1
#GR6 (Green)	2
#BL8 (Black)	3

1. Insert correctly proper die set into opened jaw.
2. Place sleeve to be compressed into proper size die groove in swaging tool.
3. Press on the forward trigger to crimp the sleeve onto cable. An audible click advises when the swage is completed.
4. Open the jaws of the tool by pressing the retract trigger. You may now start another crimp cycle of the tool. Refer to the number of compressions table (figure). For lap splices, two sleeves should be used.



BATTERY CARTRIDGE



BATTERY CHARGER



CARRYING CASE

Loos & Co., Inc. offers the complete line of Swiss-made Felco® brand cable cutters. Felco® cutters are recognized around the world for their precision and cutting capabilities. They are lightweight enough for overhead cutting, and the plastic-coated handles afford a firm, comfortable grip. A cable when crushed or deformed in cutting is difficult to use with fittings. These cutters, with unique triangular cutting jaws, never leave a frayed end.

FELCO C7 CABLE CUTTER

Capacity: 5/32" diameter. For use with #GO3 (gold)
and #OR4 (orange) cable
Length: 7.5" (190 mm)
Weight: 9.5 oz. (270 g)



FELCO C9 CABLE CUTTER

Replacement parts available from stock.



Capacity: 1/4" diameter. For use with #GR6
(green) and #BL8 (black) cable
Length: 13" (325 mm)
Weight: 1.5 lbs. (750 g)

High-Strength Blades

Hardened and tempered blades for cutting the strongest of cables.

Triangular Cutting Action

Felco®'s innovative triangular cut allows you to progressively cut cable wires at the same time, to avoid squishing the strands. Thanks to this feature, it is generally not necessary to tie the cable before the cut.

Forged Aluminum Handles

Lightweight, strong, and sturdy thanks to special aluminum alloys and advanced precision forging methods.

INSTRUCTIONS FOR LAP SPLICING OF STEEL CABLE WITH LOCOLOC® SWAGERS

Cable splicing is much easier if the cable is cut clean without frayed ends. We highly recommend FELCO C7 or C9 cable cutters as shown on our website (www.loosseismicbracing.com).

Sleeves elongate after compression. To assure maximum holding allow the end of the cable to extend one cable diameter length beyond the sleeve after it is compressed (see illustration at right). The chart below indicates the recommended number of compressions for each size of sleeve to obtain maximum holding. Keep the jaws of the swager at right angles to the sleeve being compressed, making sure the sleeve is aligned in the jaw grooves. Then close the handles of the swager completely.

Lap splices can be used to extend a seismic cable that falls short of reaching a desired length or mounting point. Note: for lap splices, at least two oval sleeves should be used. See figure to the right.

Each Loos & Co. LOCOLOC® Swager is designed to work with one or more spec size sleeves. **FOR USE ON ALL METAL CONSTRUCTION CABLES, 7x7 & 7x19.** You will not obtain performance if you do not use the proper swager and sleeve combination. All compressions must be gauged to assure maximum holding strength.

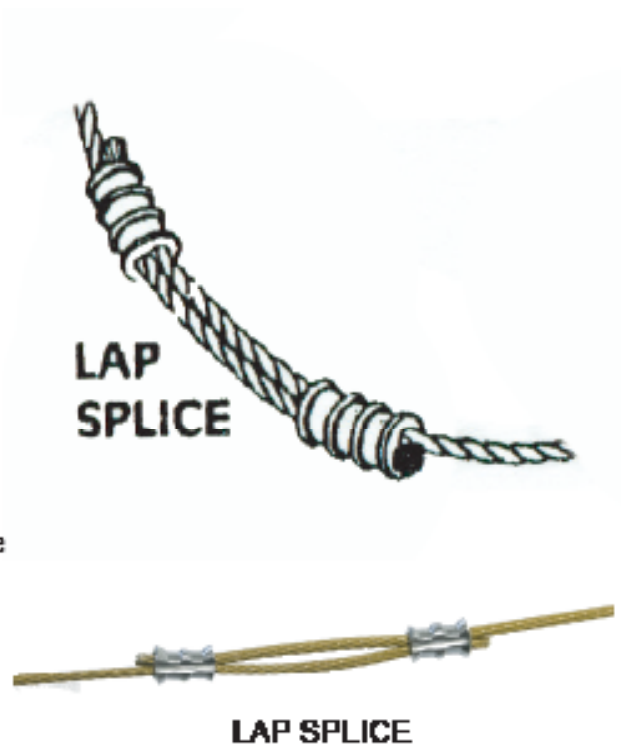

Cable Size	Number of Compressions
#GO3 (Gold)	2
#OR4 (Orange)	2
#GR6 (Green)	3
#BL8 (Black)	3

DESCRIPTION OF STANDARD CABLE KIT PART NUMBERS

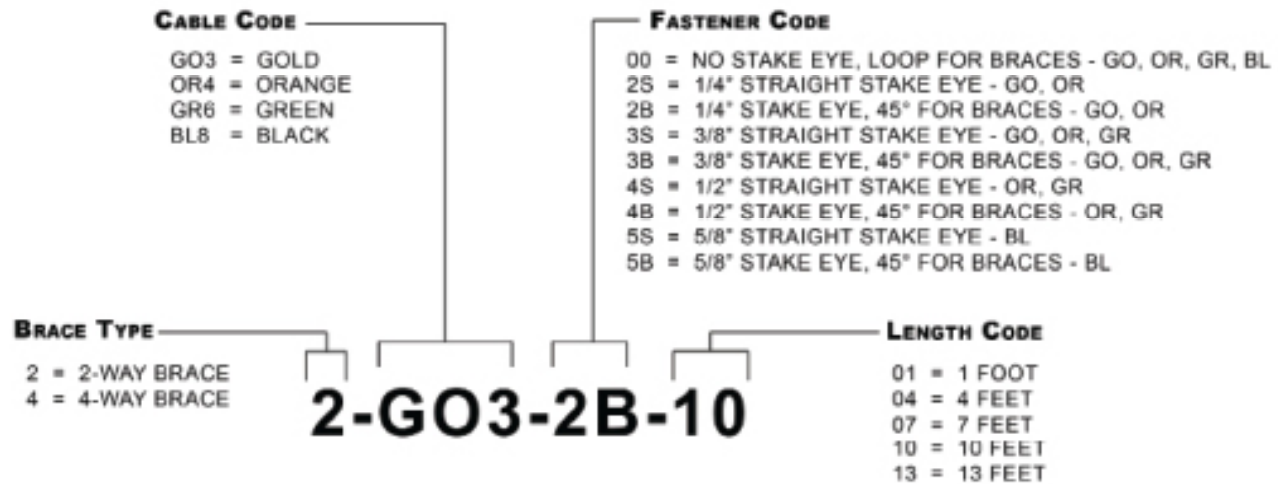

DETAILED CABLE KIT PART NUMBERS

1. Choose your brace type:

Brace Type	Description	To Fit Cable	Fastener Code
2	Two-Way	All	All
4	Four-Way	All	00, 2B, 3B, 4B, 5B

2: Choose the cable that best fits your load requirement:

Cable Code	Description	Fastener Code
GO3	Gold, 418 lb. Load Rating	00, 2S, 2B, 3S, 3B
OR4	Orange, 770 lb. Load Rating	00, 2S, 2B, 3S, 3B, 4S, 4B
GR6	Green, 1360 lb. Load Rating	00, 3S, 3B, 4S, 4B
BL8	Black, 3180 lb. Load Rating	00, 5S, 5B

3. Choose the fastener that best fits your requirement:

Fastener Code	Description	To Fit Cable
00	No Stake Eye, Loop	GO, OR, GR, BL
2S	1/4" Straight Stake Eye	GO, OR
2B	1/4" 45° Stake Eye	GO, OR
3S	3/8" Straight Stake Eye	GO, OR, GR
3B	3/8" 45° Stake Eye	GO, OR, GR
4S	1/2" Straight Stake Eye	OR, GR
4B	1/2" 45° Stake Eye	OR, GR
5S	5/8" Straight Stake Eye	BL
5B	5/8" 45° Stake Eye	BL

4. Choose desired brace length:

Length Code	Description	To Fit Cable
01	1 foot (+4 ft. extra)	All
04	4 feet (+4 ft. extra)	All
07	7 feet (+4 ft. extra)	All
10	10 feet (+4 ft. extra)	All
13	13 feet (+4 ft. extra)	All

PRODUCTS

Seismic Bracing Cable Size #G03 (Gold)



Certified Minimum Break Strength (lbs)	Allowable Load at 90° (lbs)	Allowable Load at 30° - 44° (lbs)	Allowable Load at 45° - 59° (lbs)	Allowable Load at 60° - 89° (lbs)	Min. Cable Diameter (in.)	Max. Cable Diameter (in.)
920	418	209	295	361	0.09375	0.10575

Wire Construction	Number of Wires	Nom. Dia. of Wires (in.)	Min. Stress at 0.7% Extension Under Load	Min. Ultimate Tensile Strength
7 x 7	49	.010 to .013	150,000 PSI	300,000 PSI

Applied Load (lbs)	Applied Load (% of Min. Break Strength)	% Elongation at Applied Load	Modulus of Elasticity
92	10%	0.15%	12.7 x 10 ⁶
184	20%	0.28%	14.6 x 10 ⁶
276	30%	0.40%	15.8 x 10 ⁶
368	40%	0.48%	17.7 x 10 ⁶
418	45.43%	0.54%	17.5 x 10 ⁶

*45.43% is equal to the allowable working load (break strength ÷ 2.2)

Seismic Bracing Cable Size #OR4 (Orange)



Certified Minimum Break Strength (lbs)	Allowable Load at 90° (lbs)	Allowable Load at 30° - 44° (lbs)	Allowable Load at 45° - 59° (lbs)	Allowable Load at 60° - 89° (lbs)	Min. Cable Diameter (in.)	Max. Cable Diameter (in.)
1,700	770	385	544	666	.125	.139

Wire Construction	Number of Wires	Nom. Dia. of Wires (in.)	Min. Stress at 0.7% Extension Under Load	Min. Ultimate Tensile Strength
7 x 7	49	.014 to .015	150,000 PSI	300,000 PSI

Applied Load (lbs)	Applied Load (% of Min. Break Strength)	% Elongation at Applied Load	Modulus of Elasticity
170	10%	0.17%	11.0 x 10 ⁶
340	20%	0.30%	13.4 x 10 ⁶
510	30%	0.42%	14.7 x 10 ⁶
680	40%	0.52%	16.8 x 10 ⁶
773	45.43%	0.57%	17.1 x 10 ⁶

*45.43% is equal to the allowable working load (break strength ÷ 2.2)

Seismic Bracing Cable Size #GR6 (Green)



Certified Minimum Break Strength (lbs)	Allowable Load at 90° (lbs)	Allowable Load at 30° - 44° (lbs)	Allowable Load at 45° - 59° (lbs)	Allowable Load at 60° - 89° (lbs)	Min. Cable Diameter (in.)	Max. Cable Diameter (in.)
4,200	1,900	950	1,343	1,645	.1875	.2055

Wire Construction	Number of Wires	Nom. Dia. of Wires (in.)	Min. Stress at 0.7% Extension Under Load	Min. Ultimate Tensile Strength
7 x 19	133	.0125 to .016	150,000 PSI	300,000 PSI

Applied Load (lbs)	Applied Load (% of Min. Break Strength)	% Elongation at Applied Load	Modulus of Elasticity
420	10%	0.17%	12.8 x 10 ⁶
840	20%	0.31%	14.6 x 10 ⁶
1,260	30%	0.44%	15.8 x 10 ⁶
1,680	40%	0.56%	17.1 x 10 ⁶
1,909	45.43%	0.58%	17.4 x 10 ⁶

*45.43% is equal to the allowable working load (break strength ÷ 2.2)

Seismic Bracing Cable Size #BL8 (Black)



Certified Minimum Break Strength (lbs)	Allowable Load at 90° (lbs)	Allowable Load at 30° - 44° (lbs)	Allowable Load at 45° - 59° (lbs)	Allowable Load at 60° - 89° (lbs)	Min. Cable Diameter (in.)	Max. Cable Diameter (in.)
7,000	3,180	1,590	2,248	2,753	.250	.268

Wire Construction	Number of Wires	Nom. Dia. of Wires (in.)	Min. Stress at 0.7% Extension Under Load	Min. Ultimate Tensile Strength
7 x 19	133	.016 to .020	145,000 PSI	290,000 PSI

Applied Load (lbs)	Applied Load (% of Min. Break Strength)	% Elongation at Applied Load	Modulus of Elasticity
700	10%	0.20%	12.6 x 10 ⁶
1,400	20%	0.34%	14.6 x 10 ⁶
2,100	30%	0.47%	15.9 x 10 ⁶
2,800	40%	0.60%	16.3 x 10 ⁶
3,182	45.43%	0.66%	17.2 x 10 ⁶

*45.43% is equal to the allowable working load (break strength ÷ 2.2)

Zinc-Plated Oval Sleeves



Size	Cable Color	Break Strength (lbs)	Working Load (lbs)
#GO3	Gold	920	418
#OR4	Orange	1,700	770
#GR6	Green	4,200	1,900
#BL8	Black	7,000	3,180

All zinc-plated oval sleeves supplied by Loos & Co., Inc. are in full compliance with the requirements of Military-Specification MS51844, and are certified to maintain the break strength of the cable to which they are applied (for 3x7, 7x7, 7x19, and 6x19 construction).

SAF Series

Seismic Anchoring Fitting

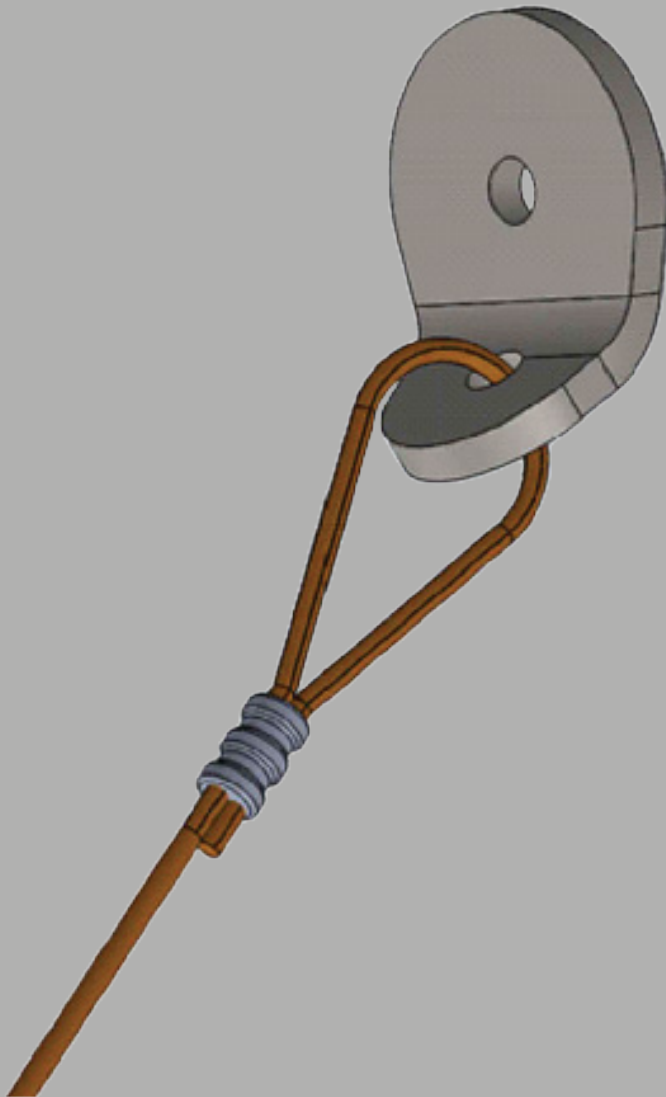

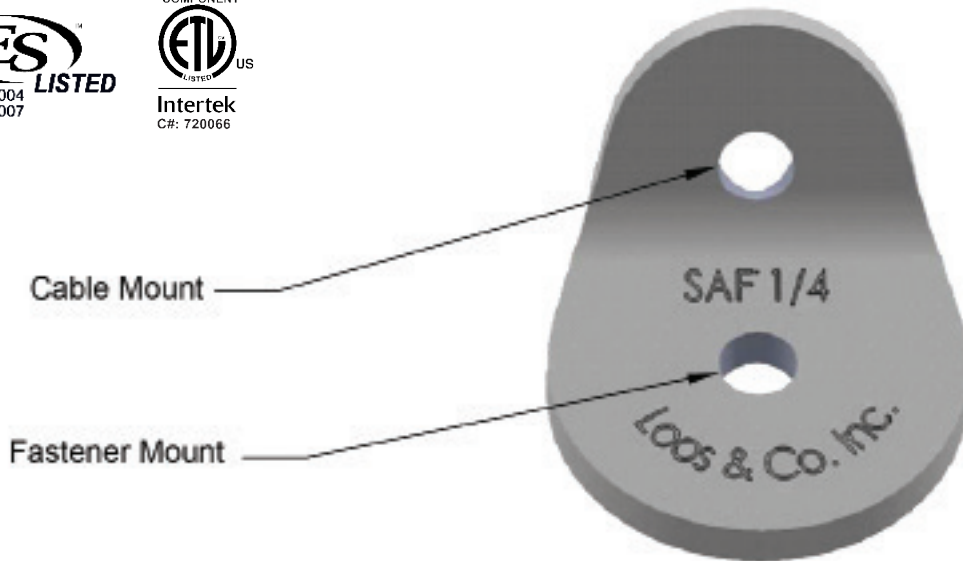

The SAF-1/4 is designed for use in attaching seismic cable bracing to steel structural members. The limitations of use are governed by the fastener diameter as a 1/4 inch (6mm) fastener is only listed for use with steel, as per NFPA-13. Will accept both metric and imperial fasteners. The cable mount will accept Gold, Orange, or Green cable.

Prying Factor			Prying Factor			Prying Factor		
Orientation 1			Orientation 2			Orientation 3		
Angle A	Angle B	Angle C	Angle D	Angle E	Angle F	Angle G	Angle H	Angle I
3.259	1.659	0.879	1.445	1.777	1.954	0.977	0.691	0.564

The SAF maintains the rated break strength of size #GO3 (gold), #OR4 (orange), and #GR6 (green) cable without the need for a thimble. The SAF may be used at both ends of the cable for anchoring equipment. SAFs are offered in 6 mounting sizes (SAF-1/4, SAF-3/8, SAF-1/2, SAF-5/8, SAF-3/4, and SAF-7/8).

UL Rated Load (lbs-f)	ICC-ES Breaking Strength (lbf)
1,900	1,700

SAF-3/8

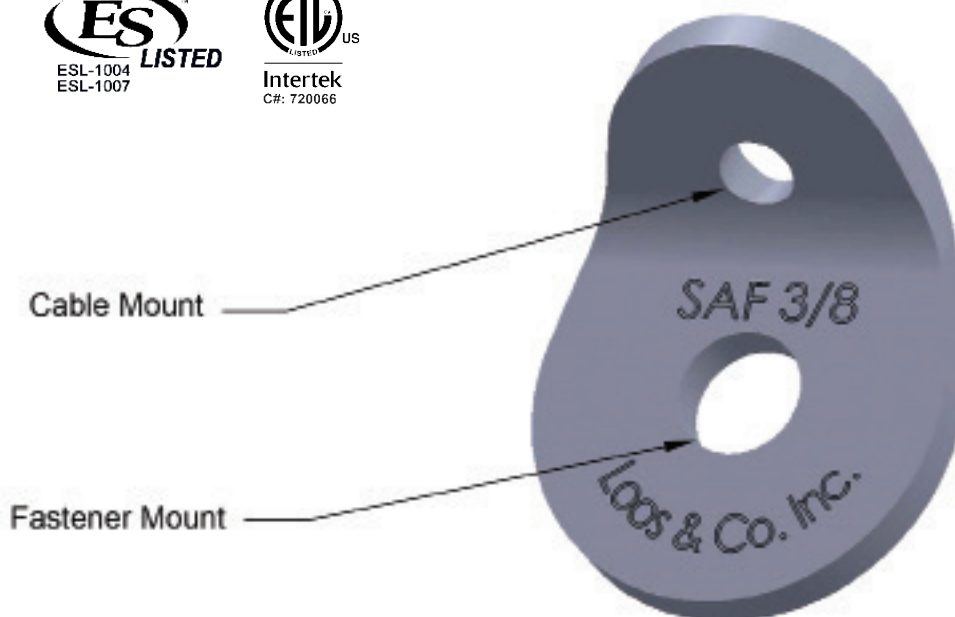

The SAF-3/8 is designed for use in attaching seismic cable bracing to steel, concrete, or wood structural members. The 3/8 inch (10mm) will accept lag bolts, bolts, and concrete anchors in both metric and imperial sizes. The cable mount will accept Gold, Orange, or Green cable.

Prying Factor			Prying Factor			Prying Factor		
Orientation 1			Orientation 2			Orientation 3		
Angle A	Angle B	Angle C	Angle D	Angle E	Angle F	Angle G	Angle H	Angle I
3.127	1.600	0.788	1.445	1.777	1.954	0.977	0.691	0.564

The SAF maintains the rated break strength of size #GO3 (gold), #OR4 (orange), and #GR6 (green) cable without the need for a thimble. The SAF may be used at both ends of the cable for anchoring equipment. SAFs are offered in 6 mounting sizes (SAF-1/4, SAF-3/8, SAF-1/2, SAF-5/8, SAF-3/4, and SAF-7/8).

UL Rated Load (lbs-f)	ICC-ES Breaking Strength (lbf)
1,900	1,700

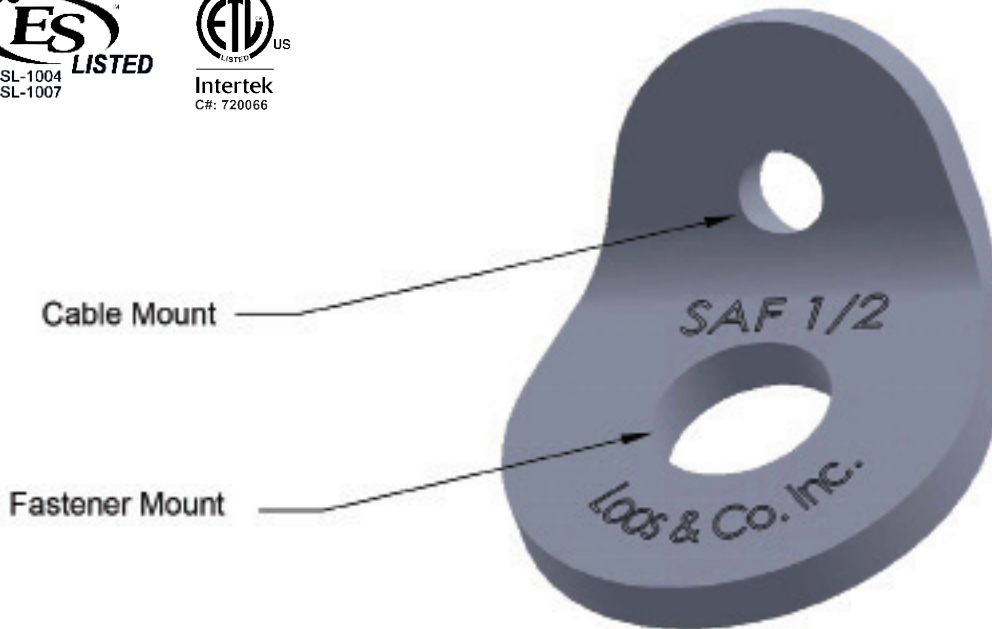

The SAF-1/2 is designed for use in attaching seismic cable bracing to steel, concrete, or wood structural members. The 1/2 inch (13mm) will accept lag bolts, bolts, and concrete anchors in both metric and imperial sizes. The cable mount will accept Gold, Orange, or Green cable.

Prying Factor			Prying Factor			Prying Factor		
Orientation 1			Orientation 2			Orientation 3		
Angle A	Angle B	Angle C	Angle D	Angle E	Angle F	Angle G	Angle H	Angle I
3.051	1.565	0.775	1.445	1.777	1.954	0.977	0.691	0.564

The SAF maintains the rated break strength of size #GO3 (gold), #OR4 (orange), and #GR6 (green) cable without the need for a thimble. The SAF may be used at both ends of the cable for anchoring equipment. SAFs are offered in 6 mounting sizes (SAF-1/4, SAF-3/8, SAF-1/2, SAF-5/8, SAF-3/4, and SAF-7/8).

UL Rated Load (lbs-f)	ICC-ES Breaking Strength (lbf)
1,900	1,700

SAF-5/8

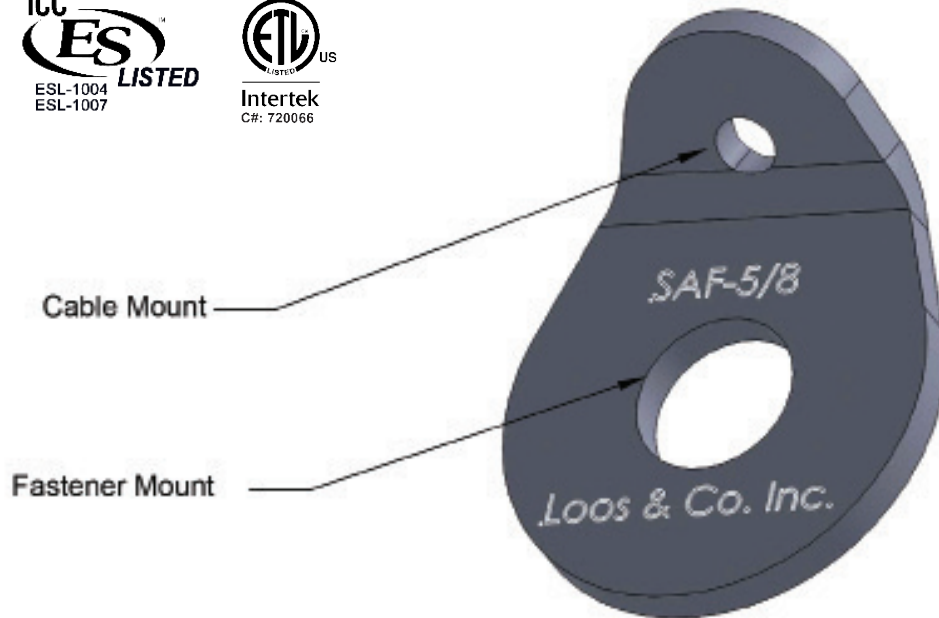

The SAF-5/8 is designed for use in attaching seismic cable bracing to steel, concrete, or wood structural members. The 5/8 inch (16mm) will accept lag bolts, bolts, and concrete anchors in both metric and imperial sizes. The cable mount will accept Gold, Orange, or Green cable.

Prying Factor			Prying Factor			Prying Factor		
Orientation 1			Orientation 2			Orientation 3		
Angle A	Angle B	Angle C	Angle D	Angle E	Angle F	Angle G	Angle H	Angle I
3.241	1.700	0.880	1.698	1.960	2.099	0.644	0.046	0.372

The SAF maintains the rated break strength of size #GO3 (gold), #OR4 (orange), and #GR6 (green) cable without the need for a thimble. The SAF may be used at both ends of the cable for anchoring equipment. SAFs are offered in 6 mounting sizes (SAF-1/4, SAF-3/8, SAF-1/2, SAF-5/8, SAF-3/4, and SAF-7/8).

UL Rated Load (lbs-f)	ICC-ES Breaking Strength (lbf)
1,900	4,200

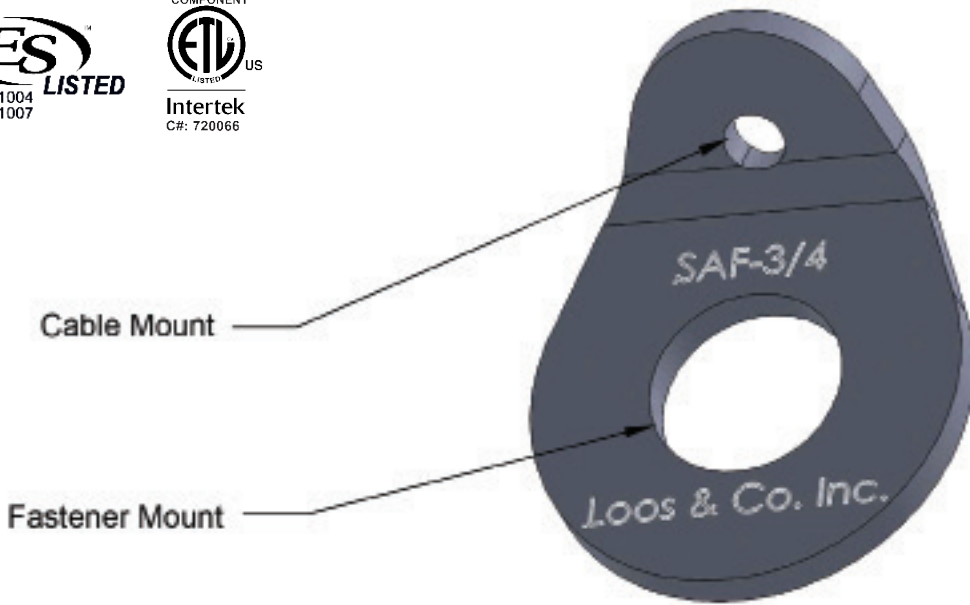

The SAF-3/4 is designed for use in attaching seismic cable bracing to steel, concrete, or wood structural members. The 3/4 inch (20mm) will accept lag bolts, bolts, and concrete anchors in both metric and imperial sizes. The cable mount will accept Gold, Orange, or Green cable.

Prying Factor		
Orientation 1		
Angle A	Angle B	Angle C
3.163	1.663	0.864

Prying Factor		
Orientation 2		
Angle D	Angle E	Angle F
1.698	1.960	2.099

Prying Factor		
Orientation 3		
Angle G	Angle H	Angle I
0.644	0.046	0.372

The SAF maintains the rated break strength of size #GO3 (gold), #OR4 (orange), and #GR6 (green) cable without the need for a thimble. The SAF may be used at both ends of the cable for anchoring equipment. SAFs are offered in 6 mounting sizes (SAF-1/4, SAF-3/8, SAF-1/2, SAF-5/8, SAF-3/4, and SAF-7/8).

UL Rated Load (lbs-f)	ICC-ES Breaking Strength (lbf)
1,900	4,200

SAF-7/8

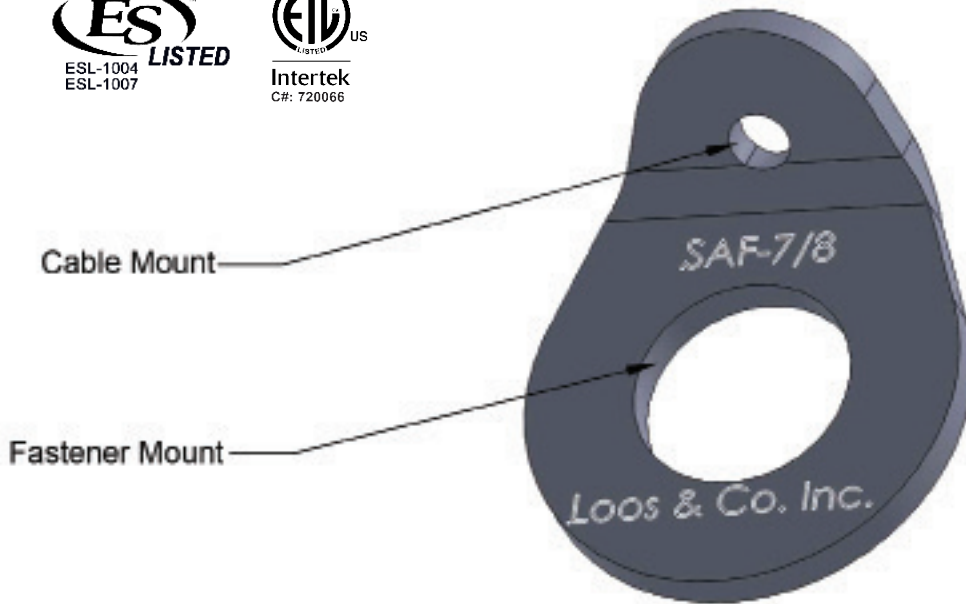

The SAF-7/8 is designed for use in attaching seismic cable bracing to steel, concrete, or wood structural members. The 7/8 inch (22mm) will accept lag bolts, bolts, and concrete anchors in both metric and imperial sizes. The cable mount will accept Gold, Orange, or Green cable.

Prying Factor		
Orientation 1		
Angle A	Angle B	Angle C
3.116	1.640	0.854

Prying Factor		
Orientation 2		
Angle D	Angle E	Angle F
1.698	1.960	2.099

Prying Factor		
Orientation 3		
Angle G	Angle H	Angle I
0.644	0.046	0.372

The SAF maintains the rated break strength of size #GO3 (gold), #OR4 (orange), and #GR6 (green) cable without the need for a thimble. The SAF may be used at both ends of the cable for anchoring equipment. SAFs are offered in 6 mounting sizes (SAF-1/4, SAF-3/8, SAF-1/2, SAF-5/8, SAF-3/4, and SAF-7/8).

UL Rated Load (lbs-f)	ICC-ES Breaking Strength (lbf)
1,900	4,200

SAFR Series

Seismic Anchoring Fitting Retrofit



SAFR-1/4

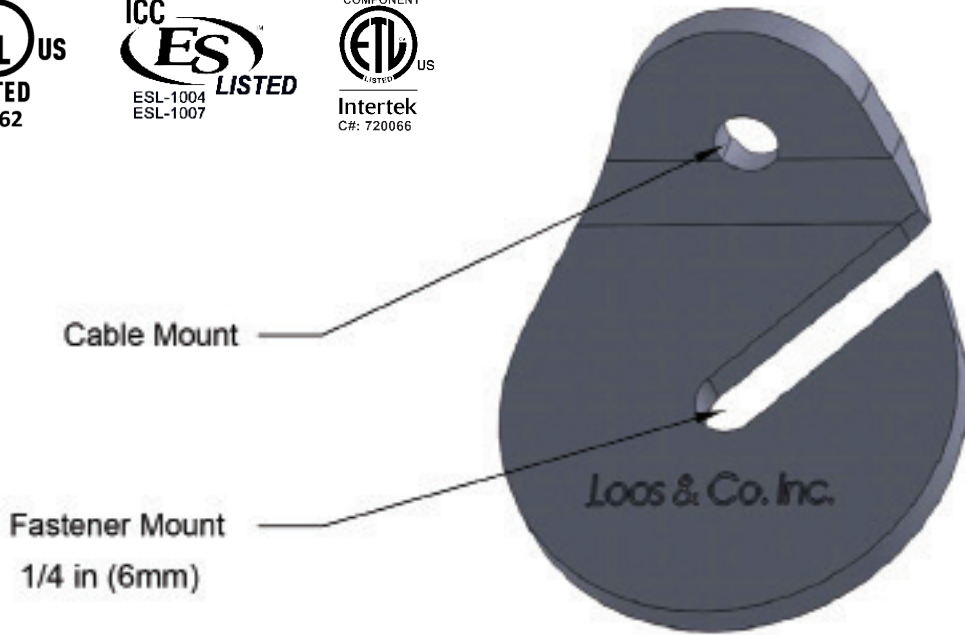

The SAFR-1/4 is designed as a retrofit Seismic Anchoring Fitting for use with pre-existing equipment and systems that require seismic bracing. The fitting is slotted to allow an existing fastener to be loosened, and the SAFR positioned without removal of the fastener. The cable mount will accept Gold or Orange cable.

Prying Factor		
Orientation 1		
Angle A	Angle B	Angle C
3.642	1.894	0.964

Prying Factor		
Orientation 2		
Angle D	Angle E	Angle F
1.698	1.960	2.099

Prying Factor		
Orientation 3		
Angle G	Angle H	Angle I
0.586	0.414	0.338

The SAFR maintains the rated break strength of size #GO3 (gold) or #OR4 (orange) cable without the need for a thimble. The SAFR may be used at both ends of the cable for anchoring equipment. SAFRs are offered in four mounting sizes (SAFR-1/4, SAFR-3/8, SAFR-1/2, SAFR-5/8).

UL Rated Load (lbs-f)	ICC-ES Breaking Strength (lbf)
770	1,700

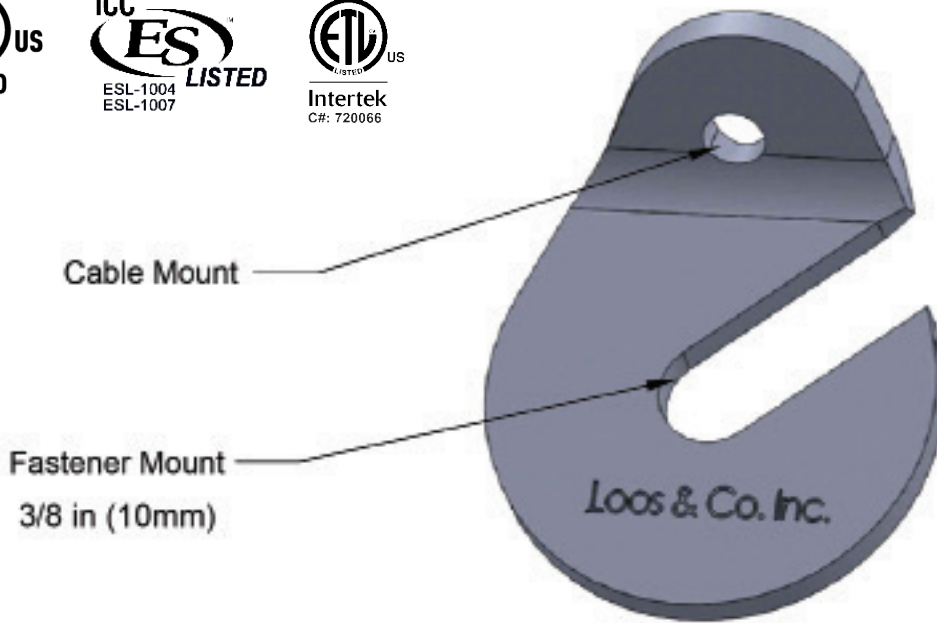

The SAFR-3/8 is designed as a retrofit Seismic Anchoring Fitting for use with pre-existing equipment and systems that require seismic bracing. The fitting is slotted to allow an existing fastener to be loosened, and the SAFR positioned without removal of the fastener. The cable mount will accept Gold or Orange cable.

Prying Factor		
Orientation 1		
Angle A	Angle B	Angle C
3.570	1.859	0.949

Prying Factor		
Orientation 2		
Angle D	Angle E	Angle F
1.698	1.960	2.099

Prying Factor		
Orientation 3		
Angle G	Angle H	Angle I
0.586	0.414	0.338

The SAFR maintains the rated break strength of size #GO3 (gold) or #OR4 (orange) cable without the need for a thimble. The SAFR may be used at both ends of the cable for anchoring equipment. SAFRs are offered in four mounting sizes (SAFR-1/4, SAFR-3/8, SAFR-1/2, SAFR-5/8).

UL Rated Load (lbs-f)	ICC-ES Breaking Strength (lbf)
770	1,700

SAFR-1/2

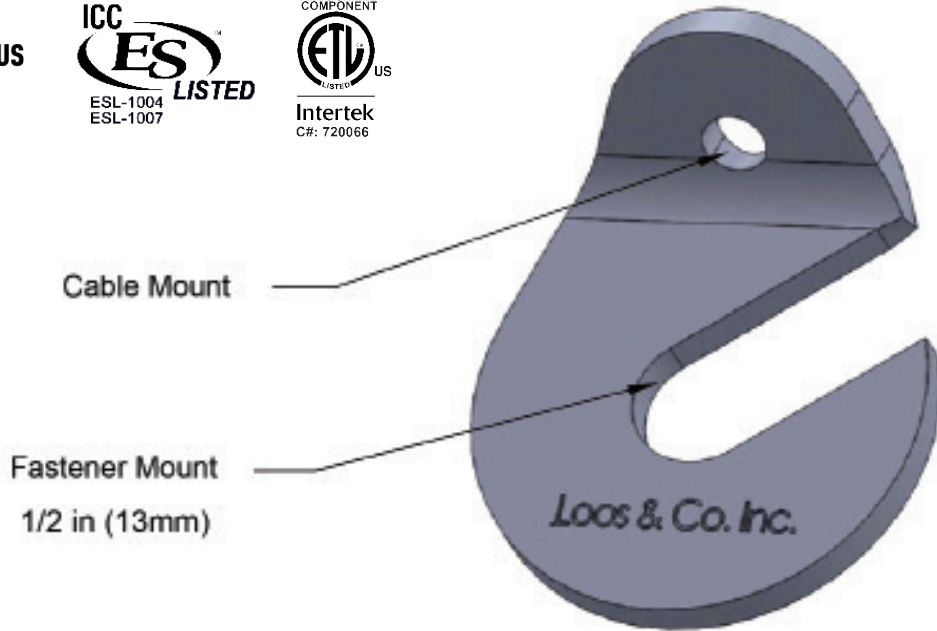

The SAFR-1/2 is designed as a retrofit Seismic Anchoring Fitting for use with pre-existing equipment and systems that require seismic bracing. The fitting is slotted to allow an existing fastener to be loosened, and the SAFR positioned without removal of the fastener. The cable mount will accept Gold or Orange cable.

Prying Factor		
Orientation 1		
Angle A	Angle B	Angle C
3.521	1.836	0.939

Prying Factor		
Orientation 2		
Angle D	Angle E	Angle F
1.698	1.960	2.099

Prying Factor		
Orientation 3		
Angle G	Angle H	Angle I
0.586	0.414	0.338

The SAFR maintains the rated break strength of size #GO3 (gold) or #OR4 (orange) cable without the need for a thimble. The SAFR may be used at both ends of the cable for anchoring equipment. SAFRs are offered in four mounting sizes (SAFR-1/4, SAFR-3/8, SAFR-1/2, SAFR-5/8).

UL Rated Load (lbs-f)	ICC-ES Breaking Strength (lbf)
770	1,700

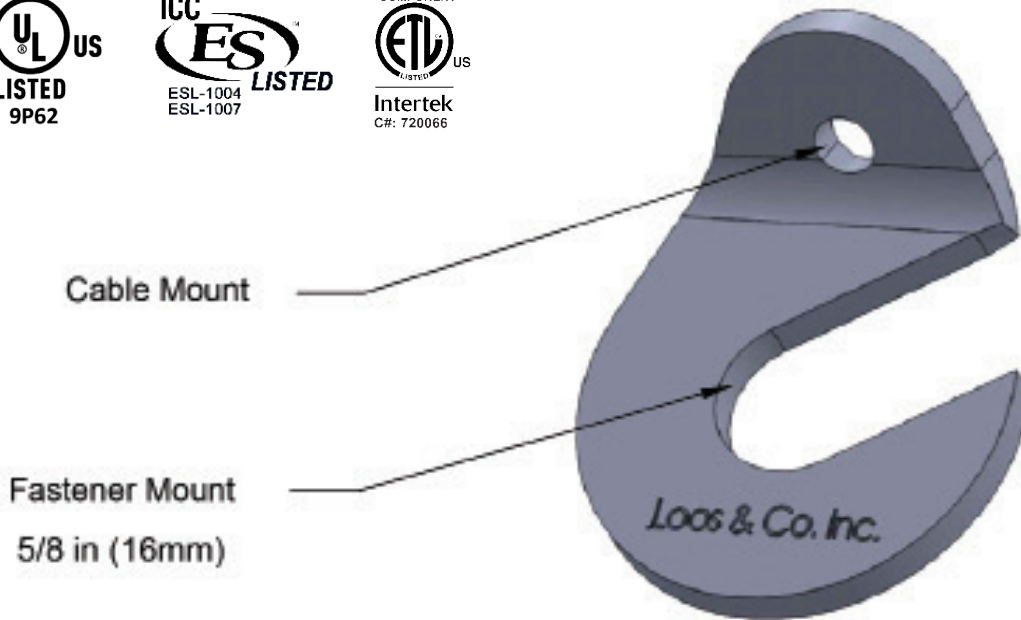

The SAFR-5/8 is designed as a retrofit Seismic Anchoring Fitting for use with pre-existing equipment and systems that require seismic bracing. The fitting is slotted to allow an existing fastener to be loosened, and the SAFR positioned without removal of the fastener. The cable mount will accept Gold or Orange cable.

Prying Factor		
Orientation 1		
Angle A	Angle B	Angle C
3.497	1.809	0.927

Prying Factor		
Orientation 2		
Angle D	Angle E	Angle F
1.698	1.960	2.099

Prying Factor		
Orientation 3		
Angle G	Angle H	Angle I
0.586	0.414	0.338

The SAFR maintains the rated break strength of size #GO3 (gold) or #OR4 (orange) cable without the need for a thimble. The SAFR may be used at both ends of the cable for anchoring equipment. SAFRs are offered in four mounting sizes (SAFR-1/4, SAFR-3/8, SAFR-1/2, SAFR-5/8).

UL Rated Load (lbs-f)	ICC-ES Breaking Strength (lbf)
770	1,700

SAF2 Series

Seismic Anchoring Fitting - 2-Way

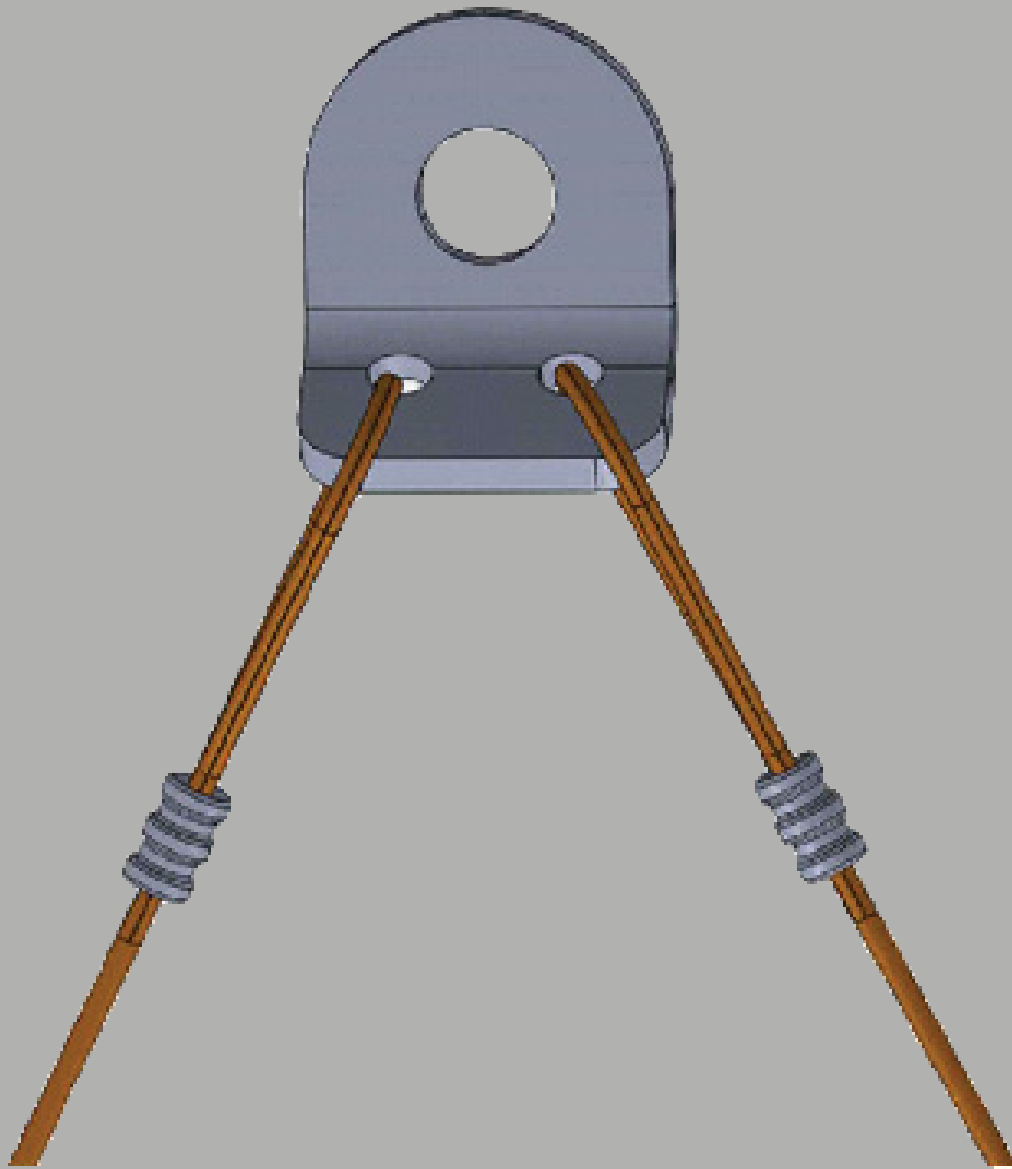

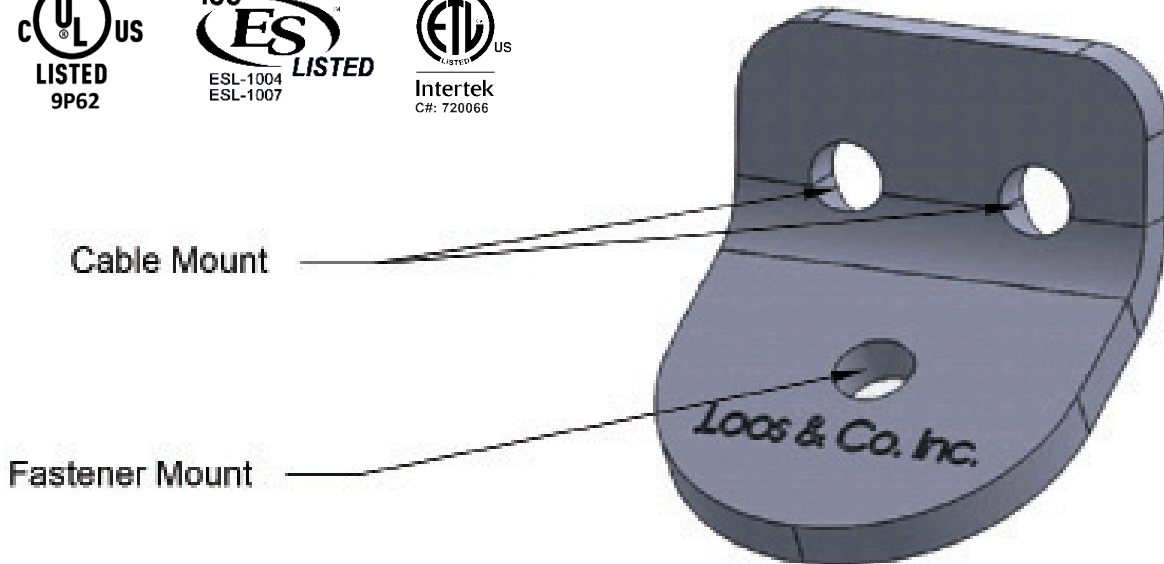

The SAF2-1/4 is designed for use in attaching seismic cable bracing to cable trays, HVAC equipment, clevis hangers, sprinkler systems, and trapeze supports for attachment to a steel, concrete, or wood structural member. The 1/4" (6mm) fastener mounting hole will accept lag bolts, bolts, threaded rod, and concrete anchors in both metric and imperial sizes. The two cable mounts will accept Gold, Orange, or Green cable, and are ideal for 2-way bracing.

Prying Factor		
Orientation 1		
Angle A	Angle B	Angle C
3.259	1.659	0.879

Prying Factor		
Orientation 2		
Angle D	Angle E	Angle F
1.445	1.777	1.954

Prying Factor		
Orientation 3		
Angle G	Angle H	Angle I
0.977	0.691	0.564

The SAF2 maintains the rated break strength of size #GO3 (gold), #OR4 (orange), and #GR6 (green) cable without the need for a thimble. The SAF2 may be used at both ends of the cable for anchoring equipment. SAF2s are offered in six mounting sizes (SAF2-1/4, SAF2-3/8, SAF2-1/2, SAF2-5/8, SAF2-3/4, and SAF2-7/8).

UL Rated Load (lbs-f)	ICC-ES Breaking Strength (lbf)
1,900	1,700

SAF2-3/8

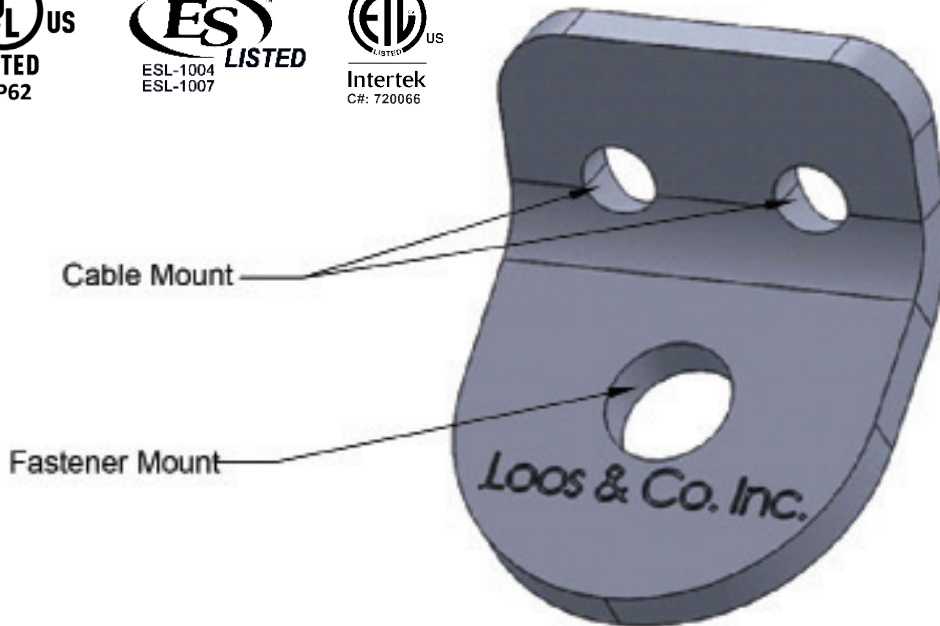

The SAF2-3/8 is designed for use in attaching seismic cable bracing to cable trays, HVAC equipment, clevis hangers, sprinkler systems, and trapeze supports for attachment to a steel, concrete, or wood structural member. The 3/8" (10mm) fastener mounting hole will accept lag bolts, bolts, threaded rod, and concrete anchors in both metric and imperial sizes. The two cable mounts will accept Gold, Orange, or Green cable, and are ideal for 2-way bracing.

Prying Factor		
Orientation 1		
Angle A	Angle B	Angle C
3.127	1.600	0.788

Prying Factor		
Orientation 2		
Angle D	Angle E	Angle F
1.445	1.777	1.954

Prying Factor		
Orientation 3		
Angle G	Angle H	Angle I
0.977	0.691	0.564

The SAF2 maintains the rated break strength of size #GO3 (gold), #OR4 (orange), and #GR6 (green) cable without the need for a thimble. The SAF2 may be used at both ends of the cable for anchoring equipment. SAF2s are offered in six mounting sizes (SAF2-1/4, SAF2-3/8, SAF2-1/2, SAF2-5/8, SAF2-3/4, and SAF2-7/8).

UL Rated Load (lbs-f)	ICC-ES Breaking Strength (lbf)
1,900	1,700

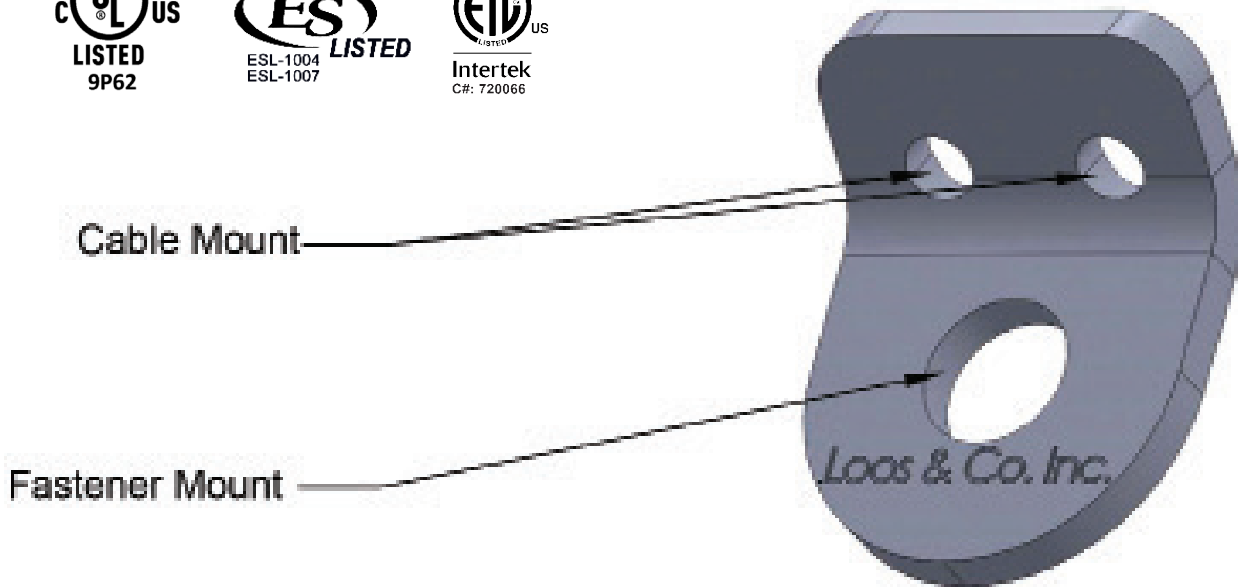

The SAF2-1/2 is designed for use in attaching seismic cable bracing to cable trays, HVAC equipment, clevis hangers, sprinkler systems, and trapeze supports for attachment to a steel, concrete, or wood structural member. The 1/2" (13mm) fastener mounting hole will accept lag bolts, bolts, threaded rod, and concrete anchors in both metric and imperial sizes. The two cable mounts will accept Gold, Orange, or Green cable, and are ideal for 2-way bracing.

Prying Factor		
Orientation 1		
Angle A	Angle B	Angle C
3.051	1.565	0.775

Prying Factor		
Orientation 2		
Angle D	Angle E	Angle F
1.445	1.777	1.954

Prying Factor		
Orientation 3		
Angle G	Angle H	Angle I
0.977	0.691	0.564

The SAF2 maintains the rated break strength of size #GO3 (gold), #OR4 (orange), and #GR6 (green) cable without the need for a thimble. The SAF2 may be used at both ends of the cable for anchoring equipment. SAF2s are offered in six mounting sizes (SAF2-1/4, SAF2-3/8, SAF2-1/2, SAF2-5/8, SAF2-3/4, and SAF2-7/8).

UL Rated Load (lbs-f)	ICC-ES Breaking Strength (lbf)
1,900	1,700

SAF2-5/8

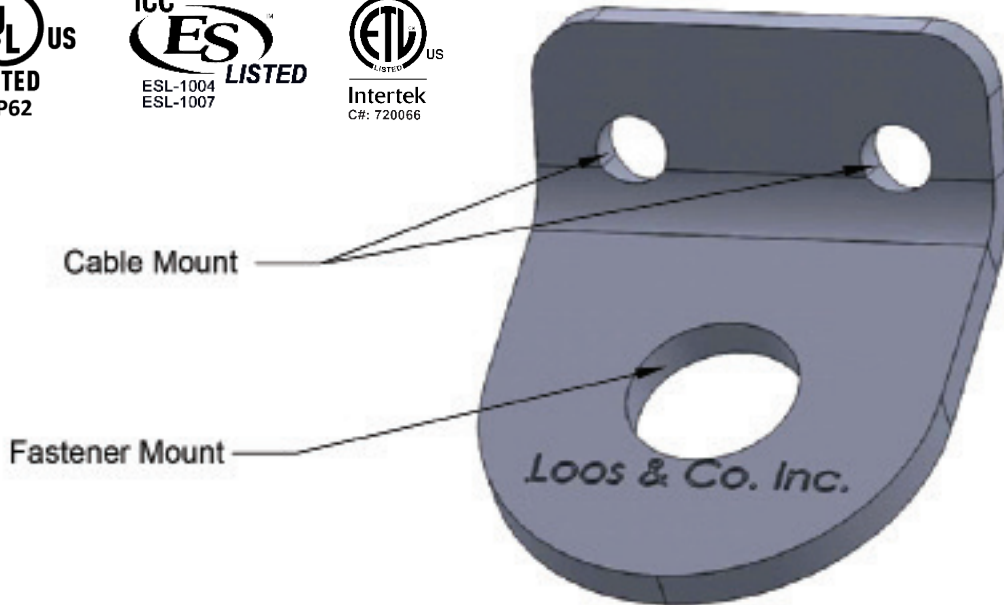

The SAF2-5/8 is designed for use in attaching seismic cable bracing to cable trays, HVAC equipment, clevis hangers, sprinkler systems, and trapeze supports for attachment to a steel, concrete, or wood structural member. The 5/8" (16mm) fastener mounting hole will accept lag bolts, bolts, threaded rod, and concrete anchors in both metric and imperial sizes. The two cable mounts will accept Gold, Orange, or Green cable, and are ideal for 2-way bracing.

Prying Factor		
Orientation 1		
Angle A	Angle B	Angle C
3.241	1.700	0.880

Prying Factor		
Orientation 2		
Angle D	Angle E	Angle F
1.698	1.960	2.099

Prying Factor		
Orientation 3		
Angle G	Angle H	Angle I
0.644	0.046	0.372

The SAF2 maintains the rated break strength of size #GO3 (gold), #OR4 (orange), and #GR6 (green) cable without the need for a thimble. The SAF2 may be used at both ends of the cable for anchoring equipment. SAF2s are offered in six mounting sizes (SAF2-1/4, SAF2-3/8, SAF2-1/2, SAF2-5/8, SAF2-3/4, and SAF2-7/8).

UL Rated Load (lbs-f)	ICC-ES Breaking Strength (lbf)
1,900	4,200

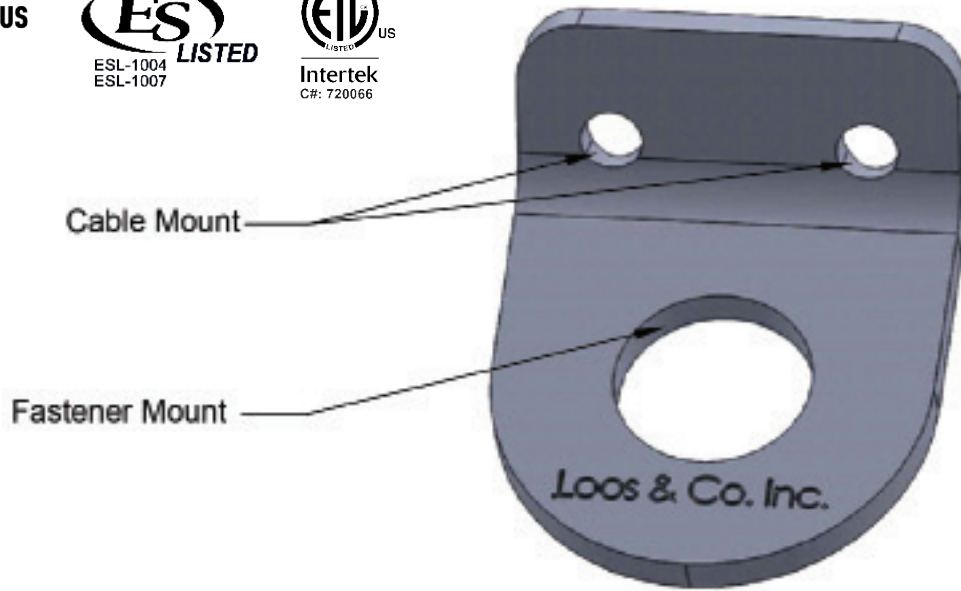

The SAF2-3/4 is designed for use in attaching seismic cable bracing to cable trays, HVAC equipment, clevis hangers, sprinkler systems, and trapeze supports for attachment to a steel, concrete, or wood structural member. The 3/4" (20mm) fastener mounting hole will accept lag bolts, bolts, threaded rod, and concrete anchors in both metric and imperial sizes. The two cable mounts will accept Gold, Orange, or Green cable, and are ideal for 2-way bracing.

Prying Factor		
Orientation 1		
Angle A	Angle B	Angle C
3.163	1.663	0.864

Prying Factor		
Orientation 2		
Angle D	Angle E	Angle F
1.698	1.960	2.099

Prying Factor		
Orientation 3		
Angle G	Angle H	Angle I
0.644	0.455	0.372

The SAF2 maintains the rated break strength of size #GO3 (gold), #OR4 (orange), and #GR6 (green) cable without the need for a thimble. The SAF2 may be used at both ends of the cable for anchoring equipment. SAF2s are offered in six mounting sizes (SAF2-1/4, SAF2-3/8, SAF2-1/2, SAF2-5/8, SAF2-3/4, and SAF2-7/8).

UL Rated Load (lbs-f)	ICC-ES Breaking Strength (lbf)
1,900	4,200

SAF2-7/8

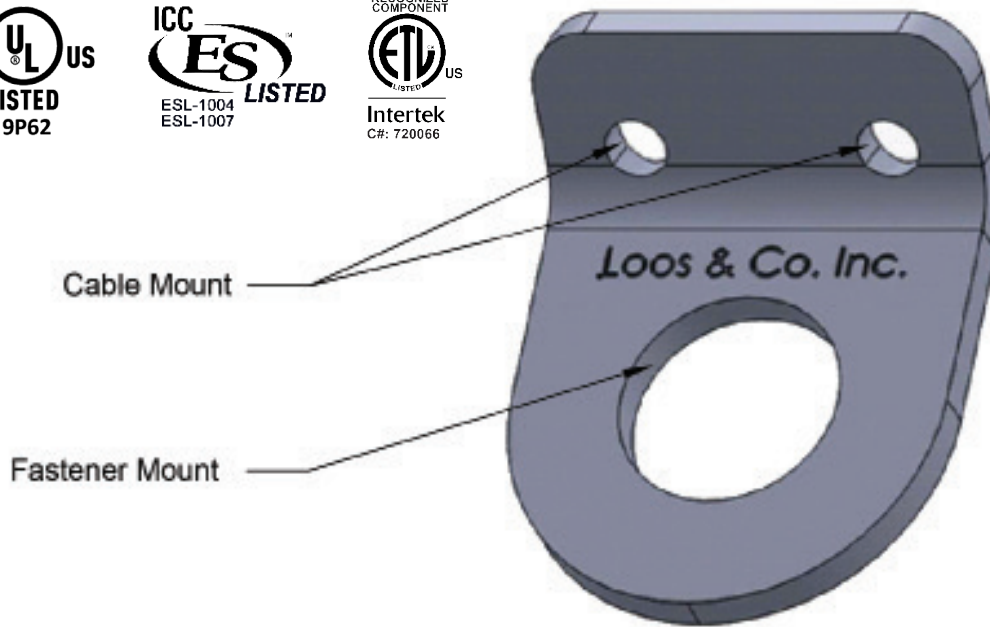

The SAF2-7/8 is designed for use in attaching seismic cable bracing to cable trays, HVAC equipment, clevis hangers, sprinkler systems, and trapeze supports for attachment to a steel, concrete, or wood structural member. The 7/8" (22mm) fastener mounting hole will accept lag bolts, bolts, threaded rod, and concrete anchors in both metric and imperial sizes. The two cable mounts will accept Gold, Orange, or Green cable, and are ideal for 2-way bracing.

Prying Factor		
Orientation 1		
Angle A	Angle B	Angle C
3.116	1.640	0.854

Prying Factor		
Orientation 2		
Angle D	Angle E	Angle F
1.698	1.960	2.099

Prying Factor		
Orientation 3		
Angle G	Angle H	Angle I
0.644	0.455	0.372

The SAF2 maintains the rated break strength of size #GO3 (gold), #OR4 (orange), and #GR6 (green) cable without the need for a thimble. The SAF2 may be used at both ends of the cable for anchoring equipment. SAF2s are offered in six mounting sizes (SAF2-1/4, SAF2-3/8, SAF2-1/2, SAF2-5/8, SAF2-3/4, and SAF2-7/8).

UL Rated Load (lbs-f)	ICC-ES Breaking Strength (lbf)
1,900	4,200

SAF2R Series

**Seismic Anchoring Fitting
Retrofit - 2-Way**

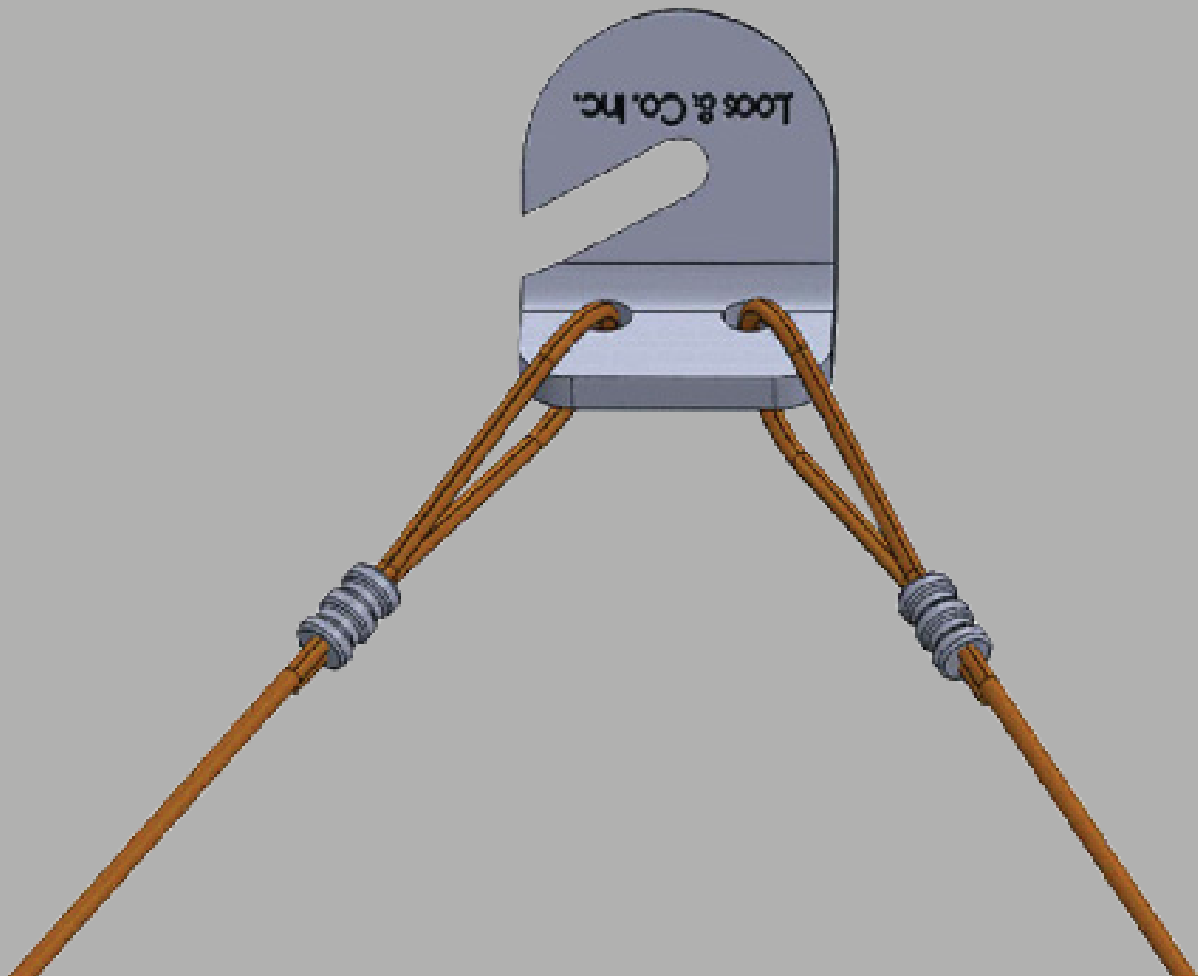

SAF2R-1/4

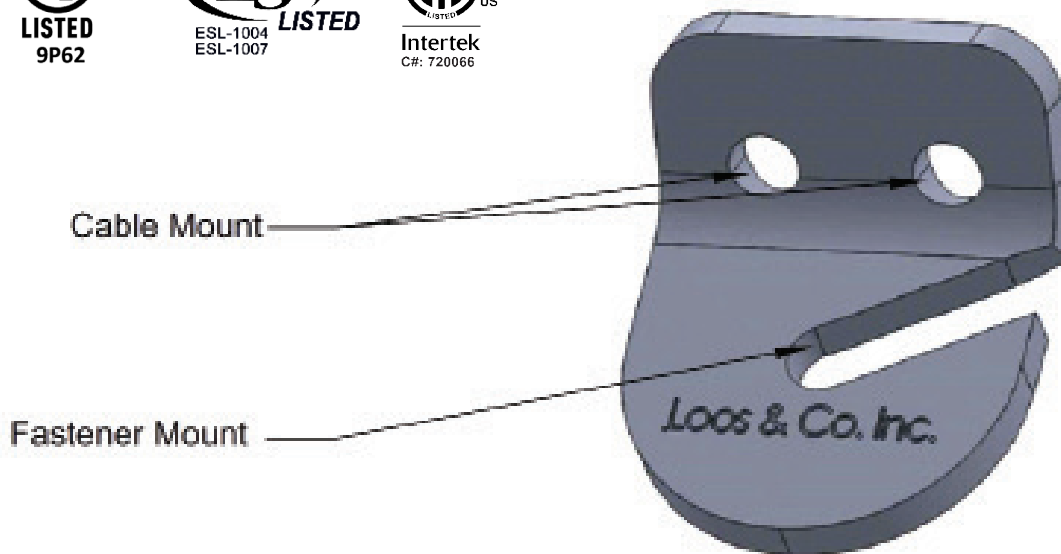

The SAF2R-1/4 is designed for use in attaching seismic cable bracing to cable trays, HVAC equipment, clevis hangers, sprinkler systems, and trapeze supports in a retrofit environment. The fitting is slotted to allow an existing fastener to be loosened, and the SAF2R positioned without removal of the fastener. The 1/4" (6mm) fastener mounting hole will accept lag bolts, bolts, threaded rod, and concrete anchors in both metric and imperial sizes. The two cable mounts will accept Gold or Orange cable, and are ideal for 2-way bracing.

Prying Factor		
Orientation 1		
Angle A	Angle B	Angle C
3.642	1.894	0.964

Prying Factor		
Orientation 2		
Angle D	Angle E	Angle F
1.698	1.960	2.099

Prying Factor		
Orientation 3		
Angle G	Angle H	Angle I
0.586	0.414	0.338

The SAF2R maintains the rated break strength of size #GO3 (gold) and #OR4 (orange) cable without the need for a thimble. The SAF2R may be used at both ends of the cable for anchoring equipment. SAF2Rs are offered in four mounting sizes (SAF2R-1/4, SAF2R-3/8, SAF2R-1/2, and SAF2R-5/8).

UL Rated Load (lbs-f)	ICC-ES Breaking Strength (lbf)
770	1,700

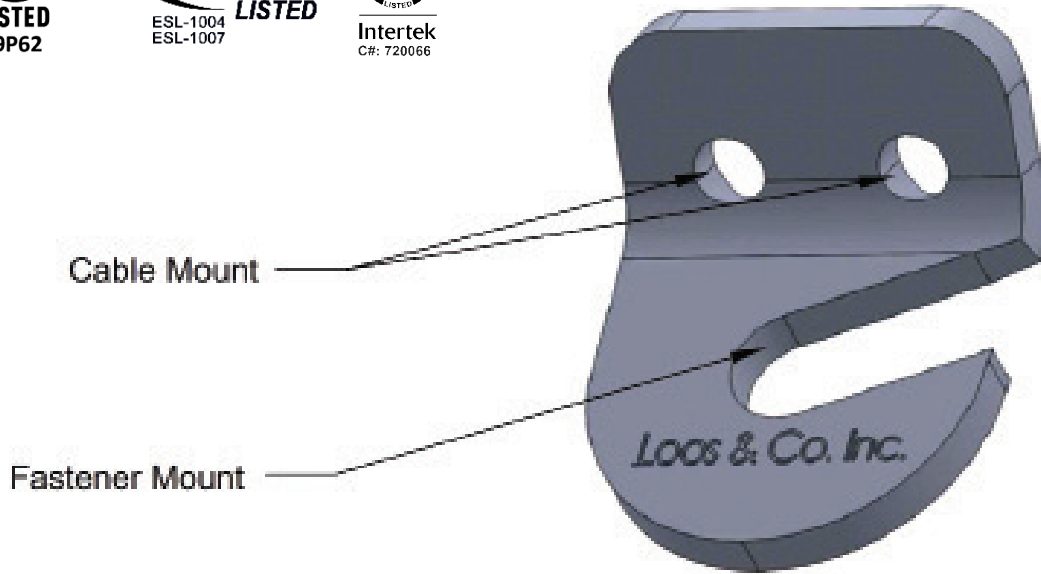

The SAF2R-3/8 is designed for use in attaching seismic cable bracing to cable trays, HVAC equipment, clevis hangers, sprinkler systems, and trapeze supports in a retrofit environment. The fitting is slotted to allow an existing fastener to be loosened, and the SAF2R positioned without removal of the fastener. The 3/8" (10mm) fastener mounting hole will accept lag bolts, bolts, threaded rod, and concrete anchors in both metric and imperial sizes. The two cable mounts will accept Gold or Orange cable, and are ideal for 2-way bracing.

Prying Factor		
Orientation 1		
Angle A	Angle B	Angle C
3.570	1.859	0.949

Prying Factor		
Orientation 2		
Angle D	Angle E	Angle F
1.698	1.960	2.099

Prying Factor		
Orientation 3		
Angle G	Angle H	Angle I
0.586	0.414	0.338

The SAF2R maintains the rated break strength of size #GO3 (gold) and #OR4 (orange) cable without the need for a thimble. The SAF2R may be used at both ends of the cable for anchoring equipment. SAF2Rs are offered in four mounting sizes (SAF2R-1/4, SAF2R-3/8, SAF2R-1/2, and SAF2R-5/8).

UL Rated Load (lbs-f)	ICC-ES Breaking Strength (lbf)
770	1,700

SAF2R-1/2

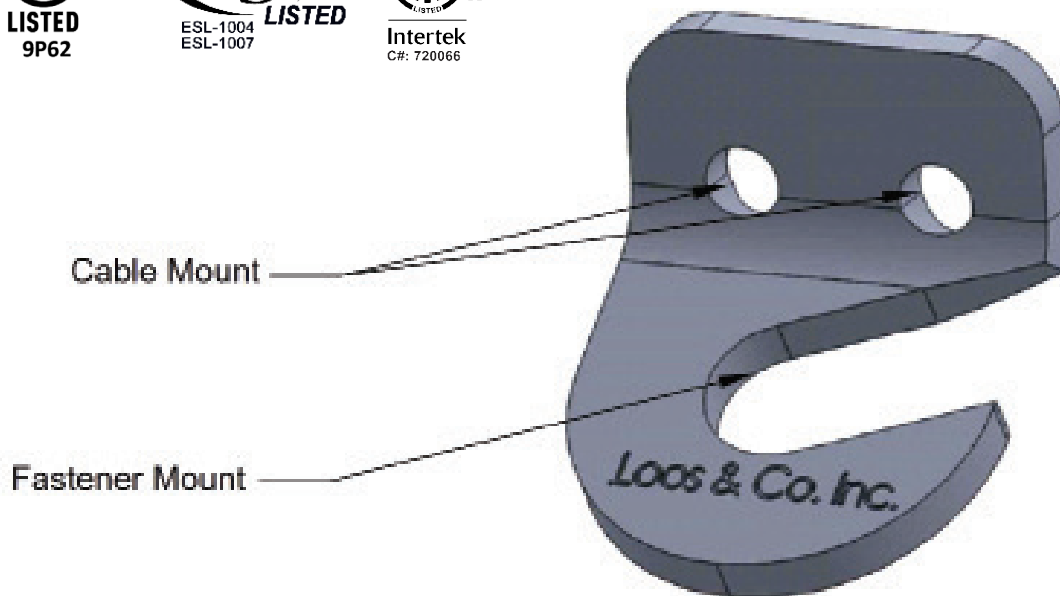

The SAF2R-1/2 is designed for use in attaching seismic cable bracing to cable trays, HVAC equipment, clevis hangers, sprinkler systems, and trapeze supports in a retrofit environment. The fitting is slotted to allow an existing fastener to be loosened, and the SAF2R positioned without removal of the fastener. The 1/2" (13mm) fastener mounting hole will accept lag bolts, bolts, threaded rod, and concrete anchors in both metric and imperial sizes. The two cable mounts will accept Gold or Orange cable, and are ideal for 2-way bracing.

Prying Factor		
Orientation 1		
Angle A	Angle B	Angle C
3.521	1.836	0.939

Prying Factor		
Orientation 2		
Angle D	Angle E	Angle F
1.698	1.960	2.099

Prying Factor		
Orientation 3		
Angle G	Angle H	Angle I
0.586	0.414	0.338

The SAF2R maintains the rated break strength of size #GO3 (gold) and #OR4 (orange) cable without the need for a thimble. The SAF2R may be used at both ends of the cable for anchoring equipment. SAF2Rs are offered in four mounting sizes (SAF2R-1/4, SAF2R-3/8, SAF2R-1/2, and SAF2R-5/8).

UL Rated Load (lbs-f)	ICC-ES Breaking Strength (lbf)
770	1,700

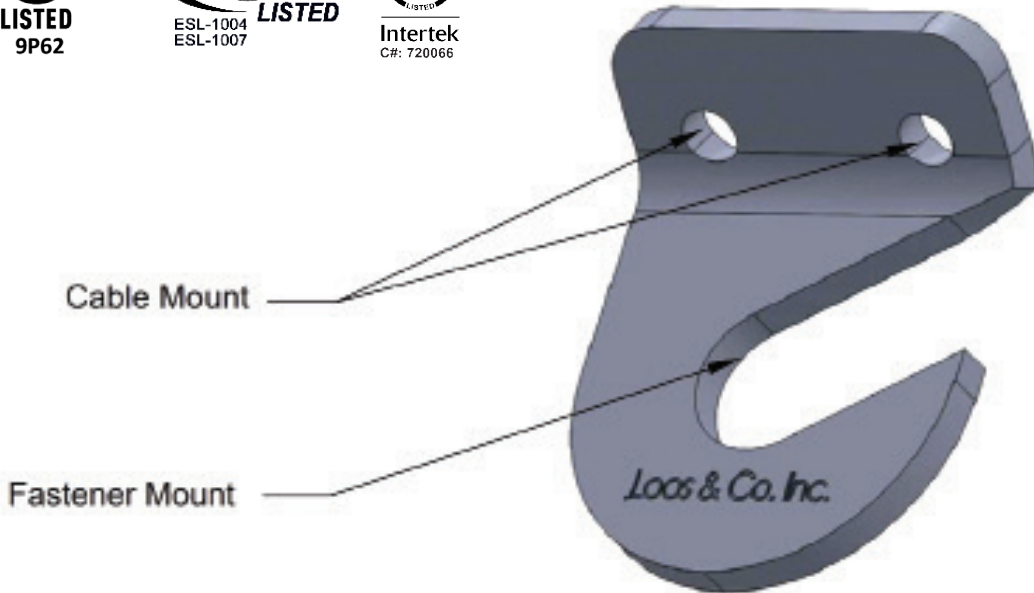

The SAF2R-5/8 is designed for use in attaching seismic cable bracing to cable trays, HVAC equipment, clevis hangers, sprinkler systems, and trapeze supports in a retrofit environment. The fitting is slotted to allow an existing fastener to be loosened, and the SAF2R positioned without removal of the fastener. The 5/8" (16mm) fastener mounting hole will accept lag bolts, bolts, threaded rod, and concrete anchors in both metric and imperial sizes. The two cable mounts will accept Gold or Orange cable, and are ideal for 2-way bracing.

Prying Factor		
Orientation 1		
Angle A	Angle B	Angle C
3.467	1.809	0.927

Prying Factor		
Orientation 2		
Angle D	Angle E	Angle F
1.698	1.960	2.099

Prying Factor		
Orientation 3		
Angle G	Angle H	Angle I
0.586	0.414	0.338

The SAF2R maintains the rated break strength of size #GO3 (gold) and #OR4 (orange) cable without the need for a thimble. The SAF2R may be used at both ends of the cable for anchoring equipment. SAF2Rs are offered in four mounting sizes (SAF2R-1/4, SAF2R-3/8, SAF2R-1/2, and SAF2R-5/8).

UL Rated Load (lbs-f)	ICC-ES Breaking Strength (lbf)
770	1,700

LPF Series

Low-Pry Fitting

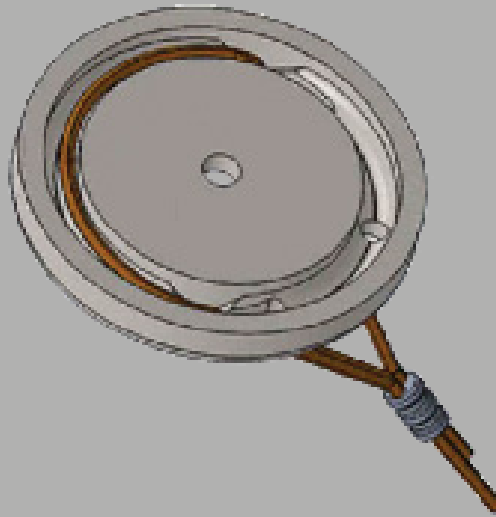



LPF Installation

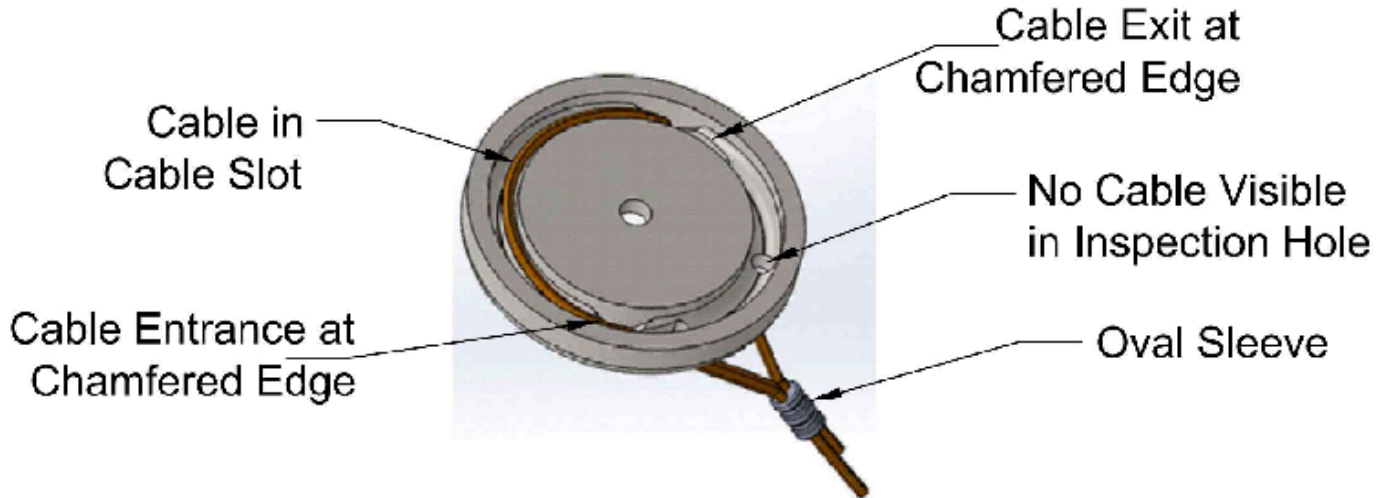

The Low-Pry Fitting (LPF), due to its design, offers a low prying effect. The cable is inserted into the slot provided, at the chamfered edge, through the cable slot and out the cable exit. The cable is then secured with the proper size oval sleeve. To ensure that the cable is properly installed, no cable should be visible through the inspection hole (opposite the proper cable slot). The LPF should be mounted with the inspection hole pointed in the direction of the brace. The cable mount will accept Gold, Orange, and Green cable.

LPF-1/4

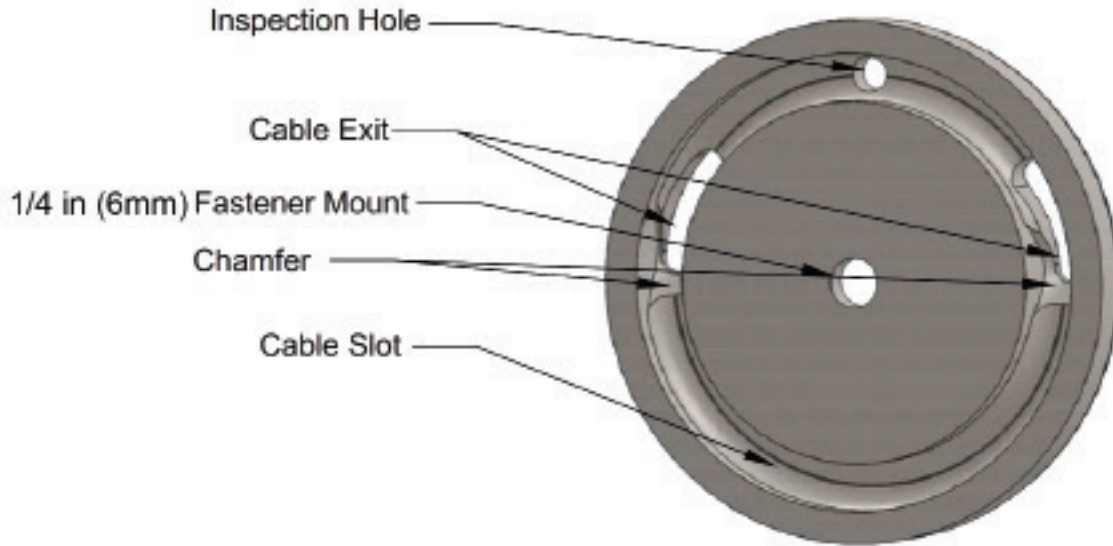

The LPF-1/4 is specifically designed to reduce the prying effect on fasteners. The cable is nested in the groove provided, and exits through two chamfered slots (to prevent damage to the outer fibers of the cable). An inspection hole is provided to ensure that the cable is placed in the correct position within the groove. The LPF has the lowest prying factor yet to be achieved. The cable mount will accept Gold, Orange, and Green cable.

Prying Factor		
Orientation 1		
Angle A	Angle B	Angle C
1.627	0.833	0.410

Prying Factor		
Orientation 2		
Angle D	Angle E	Angle F
0.673	0.818	0.895

Prying Factor		
Orientation 3		
Angle G	Angle H	Angle I
0.500	0.354	0.289

UL Rated Load (lbs-f)	ICC-ES Breaking Strength (lbf)
1,900	1,700

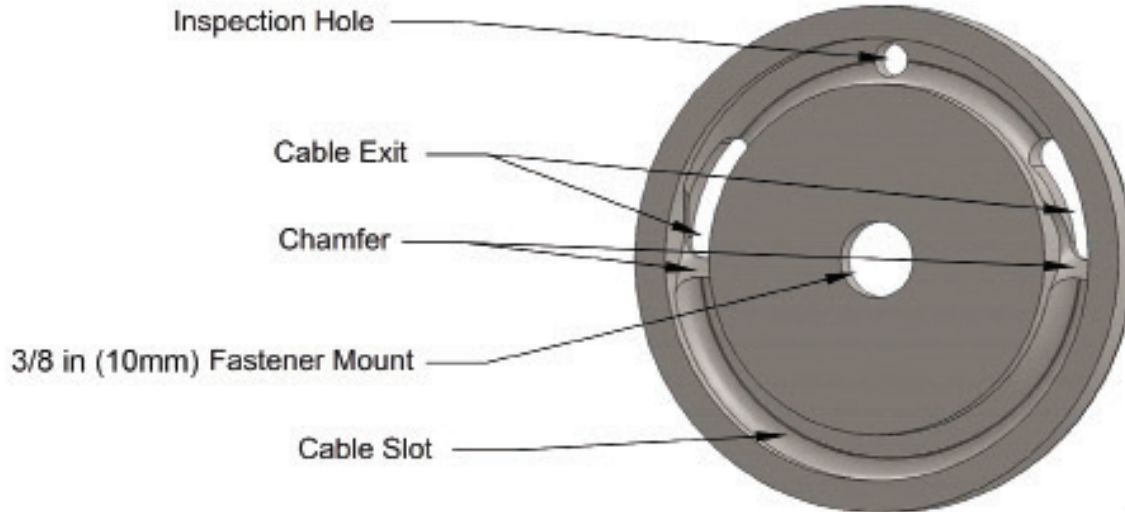

The LPF-3/8 is specifically designed to reduce the prying effect on fasteners. The cable is nested in the groove provided, and exits through two chamfered slots (to prevent damage to the outer fibers of the cable). An inspection hole is provided to ensure that the cable is placed in the correct position within the groove. The LPF has the lowest prying factor yet to be achieved. The cable mount will accept Gold, Orange, and Green cable.

Prying Factor		
Orientation 1		
Angle A	Angle B	Angle C
1.634	0.839	0.417

Prying Factor		
Orientation 2		
Angle D	Angle E	Angle F
0.673	0.818	0.895

Prying Factor		
Orientation 3		
Angle G	Angle H	Angle I
0.500	0.354	0.289

UL Rated Load (lbs-f)	ICC-ES Breaking Strength (lbf)
1,900	1,700

LPF-1/2

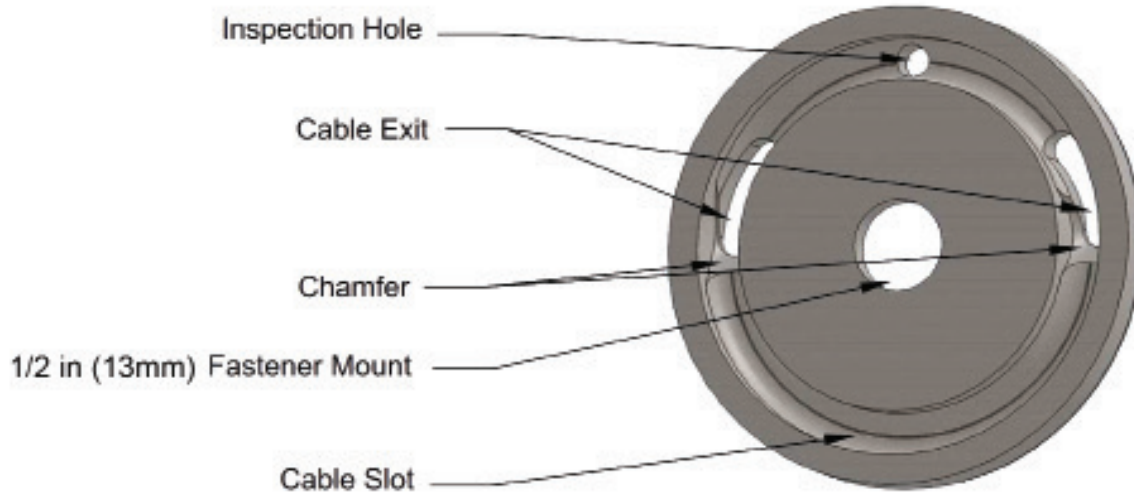

The LPF-1/2 is specifically designed to reduce the prying effect on fasteners. The cable is nested in the groove provided, and exits through two chamfered slots (to prevent damage to the outer fibers of the cable). An inspection hole is provided to ensure that the cable is placed in the correct position within the groove. The LPF has the lowest prying factor yet to be achieved. The cable mount will accept Gold, Orange, and Green cable.

Prying Factor		
Orientation 1		
Angle A	Angle B	Angle C
1.640	0.846	0.423

Prying Factor		
Orientation 2		
Angle D	Angle E	Angle F
0.673	0.818	0.895

Prying Factor		
Orientation 3		
Angle G	Angle H	Angle I
0.500	0.354	0.289

UL Rated Load (lbs-f)	ICC-ES Breaking Strength (lbf)
1,900	1,700

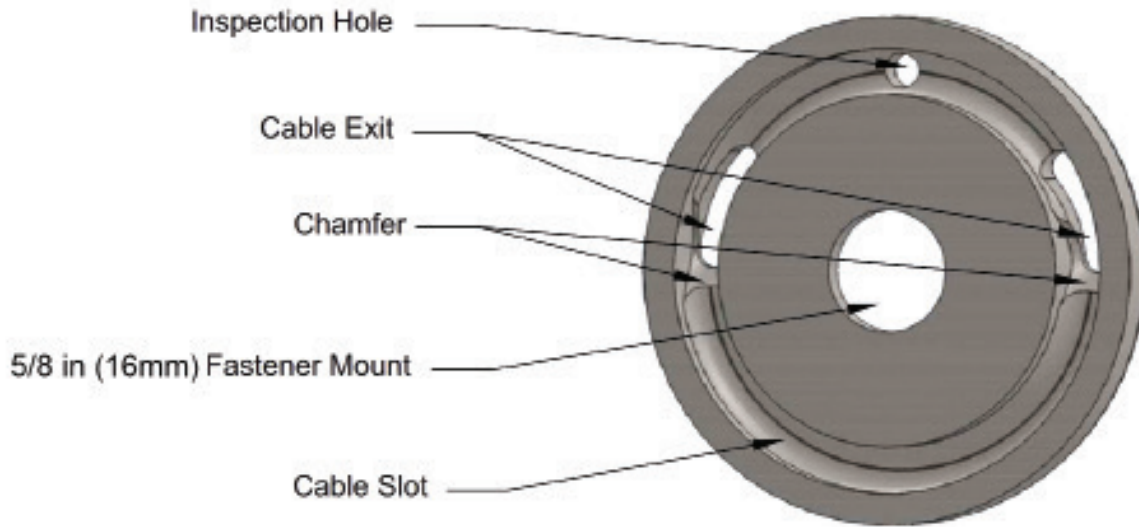

The LPF-5/8 is specifically designed to reduce the prying effect on fasteners. The cable is nested in the groove provided, and exits through two chamfered slots (to prevent damage to the outer fibers of the cable). An inspection hole is provided to ensure that the cable is placed in the correct position within the groove. The LPF has the lowest prying factor yet to be achieved. The cable mount will accept Gold, Orange, and Green cable.

Prying Factor		
Orientation 1		
Angle A	Angle B	Angle C
1.646	0.851	0.429

Prying Factor		
Orientation 2		
Angle D	Angle E	Angle F
0.673	0.818	0.895

Prying Factor		
Orientation 3		
Angle G	Angle H	Angle I
0.500	0.354	0.289

UL Rated Load (lbs-f)	ICC-ES Breaking Strength (lbf)
1,900	1,700

LPF-3/4

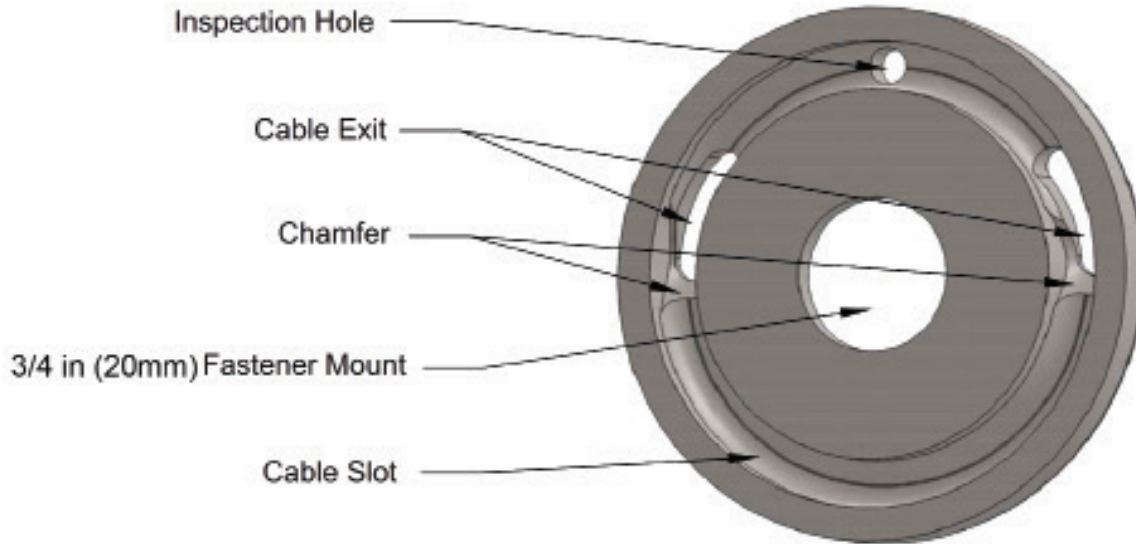

The LPF-3/4 is specifically designed to reduce the prying effect on fasteners. The cable is nested in the groove provided, and exits through two chamfered slots (to prevent damage to the outer fibers of the cable). An inspection hole is provided to ensure that the cable is placed in the correct position within the groove. The LPF has the lowest prying factor yet to be achieved. The cable mount will accept Gold, Orange, and Green cable.

Prying Factor		
Orientation 1		
Angle A	Angle B	Angle C
1.651	0.857	0.434

Prying Factor		
Orientation 2		
Angle D	Angle E	Angle F
0.673	0.818	0.895

Prying Factor		
Orientation 3		
Angle G	Angle H	Angle I
0.500	0.354	0.289

UL Rated Load (lbs-f)	ICC-ES Breaking Strength (lbf)
1,900	1,700

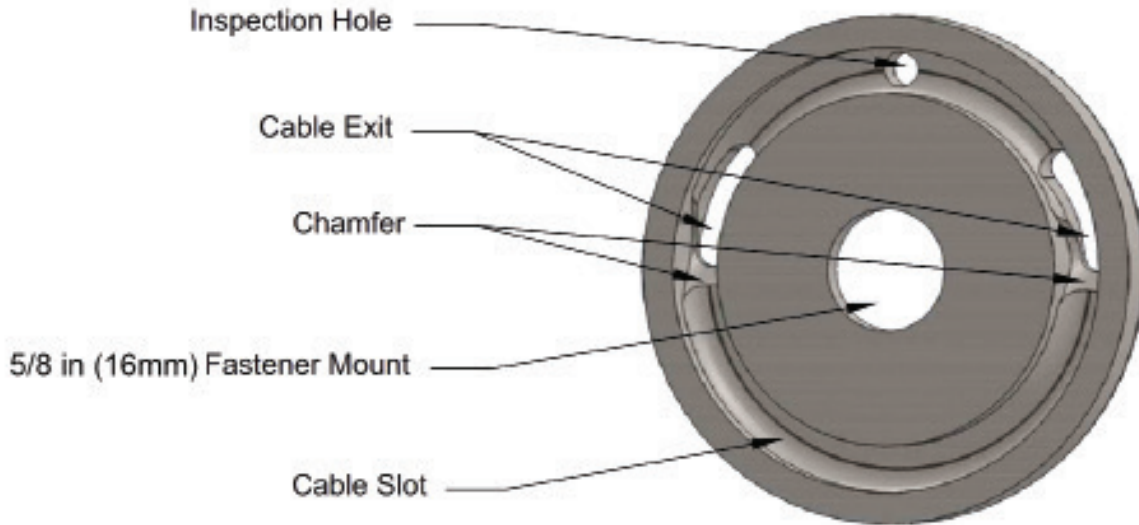

The LPF-7/8 is specifically designed to reduce the prying effect on fasteners. The cable is nested in the groove provided, and exits through two chamfered slots (to prevent damage to the outer fibers of the cable). An inspection hole is provided to ensure that the cable is placed in the correct position within the groove. The LPF has the lowest prying factor yet to be achieved. The cable mount will accept Gold, Orange, and Green cable.

Prying Factor		
Orientation 1		
Angle A	Angle B	Angle C
1.656	0.862	0.439

Prying Factor		
Orientation 2		
Angle D	Angle E	Angle F
0.673	0.818	0.895

Prying Factor		
Orientation 3		
Angle G	Angle H	Angle I
0.500	0.354	0.289

UL Rated Load (lbs-f)
1,900

Cable Kits



Gold (#G03) Cable Kit - 2-Way



The gold 2-way cable kit is available in 5 pre-cut lengths (1', 4', 7', 10', or 13' - an extra 4 feet of cable is added to any pre-cut length). This kit contains 2 lengths of cable with two options of terminals. One option includes a factory-installed stake eye on one end (in 1/4" or 3/8" fastener mounting sizes, either straight or bent on a 45° angle) with 2 oval sleeves. The other option provides 2 cable lengths with no stake eye and 4 oval sleeves, for bar joist loop installation or for use with all sizes of the SAF, SAFR, SAF2, SAF2R, or LPF fittings. Listed for Lateral and Longitudinal installations.

The gold cable kit has a rated working load of 418 pounds and is certified to achieve a minimum break strength of 920 pounds.

Orange (#OR4) Cable Kit - 2-Way



The orange 2-way cable kit is available in 5 pre-cut lengths (1', 4', 7', 10', or 13' - an extra 4 feet of cable is added to any pre-cut length). This kit contains 2 lengths of cable with two options of terminals. One option includes a factory-installed stake eye on one end (in 1/4", 3/8", or 1/2" fastener mounting sizes, either straight or bent on a 45° angle) with 2 oval sleeves. The other option provides 2 cable lengths with no stake eye and 4 oval sleeves, for bar joist loop installation or for use with all sizes of the SAF, SAFR, SAF2, SAF2R, or LPF fittings. Listed for Lateral and Longitudinal installations.

The orange cable kit has a rated working load of 770 pounds and is certified to achieve a minimum break strength of 1,700 pounds.

Green (#GR6) Cable Kit - 2-Way



The green 2-way cable kit is available in 5 pre-cut lengths (1', 4', 7', 10', or 13' - an extra 4 feet of cable is added to any pre-cut length). This kit contains 2 lengths of cable with two options of terminals. One option includes a factory-installed stake eye on one end (in 3/8" or 1/2" fastener mounting sizes, either straight or bent on a 45° angle) with 2 oval sleeves. The other option provides 2 cable lengths with no stake eye and 4 oval sleeves, for bar joist loop installation or for use with all sizes of the SAF, SAF2, or LPF fittings. Listed for Lateral and Longitudinal installations.

The green cable kit has a rated working load of 1,360 pounds and is certified to achieve a minimum break strength of 3,000 pounds. The green cable kit's rated working load and certified minimum breaking strength differs from the green cable.

Black (#BL8) Cable Kit - 2-Way



The black 2-way cable kit is available in 5 pre-cut lengths (1', 4', 7', 10', or 13' - an extra 4 feet of cable is added to any pre-cut length). This kit contains 2 lengths of cable with two options of terminals. One option includes a factory-installed stake eye on one end (in 5/8" fastener mounting size, either straight or bent on a 45° angle) with 2 oval sleeves. The other option provides 2 cable lengths with no stake eye and 4 oval sleeves for bar joist loop installation. Listed for Lateral and Longitudinal installations.

The black cable kit has a rated working load of 3,180 pounds and is certified to achieve a minimum break strength of 7,000 pounds.

Gold (#G03) Cable Kit - 4-Way



The gold 4-way cable kit is available in 5 pre-cut lengths (1', 4', 7', 10', or 13' - an extra 4 feet of cable is added to any pre-cut length). This kit contains 4 lengths of cable with two options of terminals. One option includes a factory-installed stake eye on one end (in 1/4" or 3/8" fastener mounting sizes, either straight or bent on a 45° angle) with 4 oval sleeves. The other option provides 4 cable lengths with no stake eye and 8 oval sleeves, for bar joist loop installation or for use with all sizes of the SAF, SAFR, SAF2, SAF2R, or LPF fittings. Listed for 4-way installations.

The gold cable kit has a rated working load of 418 pounds and is certified to achieve a minimum break strength of 920 pounds.

Orange (#OR4) Cable Kit - 4-Way



The orange 4-way cable kit is available in 5 pre-cut lengths (1', 4', 7', 10', or 13' - an extra 4 feet of cable is added to any pre-cut length). This kit contains 4 lengths of cable with two options of terminals. One option includes a factory-installed stake eye on one end (in 1/4", 3/8", or 1/2" fastener mounting sizes, either straight or bent on a 45° angle) with 4 oval sleeves. The other option provides 4 cable lengths with no stake eye and 8 oval sleeves, for bar joist loop installation or for use with all sizes of the SAF, SAFR, SAF2, SAF2R, or LPF fittings. Listed for 4-way installations.

The orange cable kit has a rated working load of 770 pounds and is certified to achieve a minimum break strength of 1,700 pounds.

Green (#GR6) Cable Kit - 4-Way



The green 4-way cable kit is available in 5 pre-cut lengths (1', 4', 7', 10', or 13' - an extra 4 feet of cable is added to any pre-cut length). This kit contains 4 lengths of cable with two options of terminals. One option includes a factory-installed stake eye on one end (in 3/8" or 1/2" fastener mounting sizes, either straight or bent on a 45° angle) with 4 oval sleeves. The other option provides 4 cable lengths with no stake eye and 8 oval sleeves, for bar joist loop installation or for use with all sizes of the SAF, SAF2, or LPF fittings. Listed for 4-way installations.

The green cable kit has a rated working load of 1,360 pounds and is certified to achieve a minimum break strength of 3,000 pounds. The green cable kit's rated working load and certified minimum breaking strength differs from the green cable.

Black (#BL8) Cable Kit - 4-Way



The black 4-way cable kit is available in 5 pre-cut lengths (1', 4', 7', 10', or 13' - an extra 4 feet of cable is added to any pre-cut length). This kit contains 4 lengths of cable with two options of terminals. One option includes a factory-installed stake eye on one end (in 5/8" fastener mounting size, either straight or bent on a 45° angle) with 4 oval sleeves. The other option provides 4 cable lengths with no stake eye and 8 oval sleeves for bar joist loop installation. Listed for 4-way installations.

The black cable kit has a rated working load of 3,180 pounds and is certified to achieve a minimum break strength of 7,000 pounds.

Installation Instructions

INSTRUCTIONS



Lateral Brace

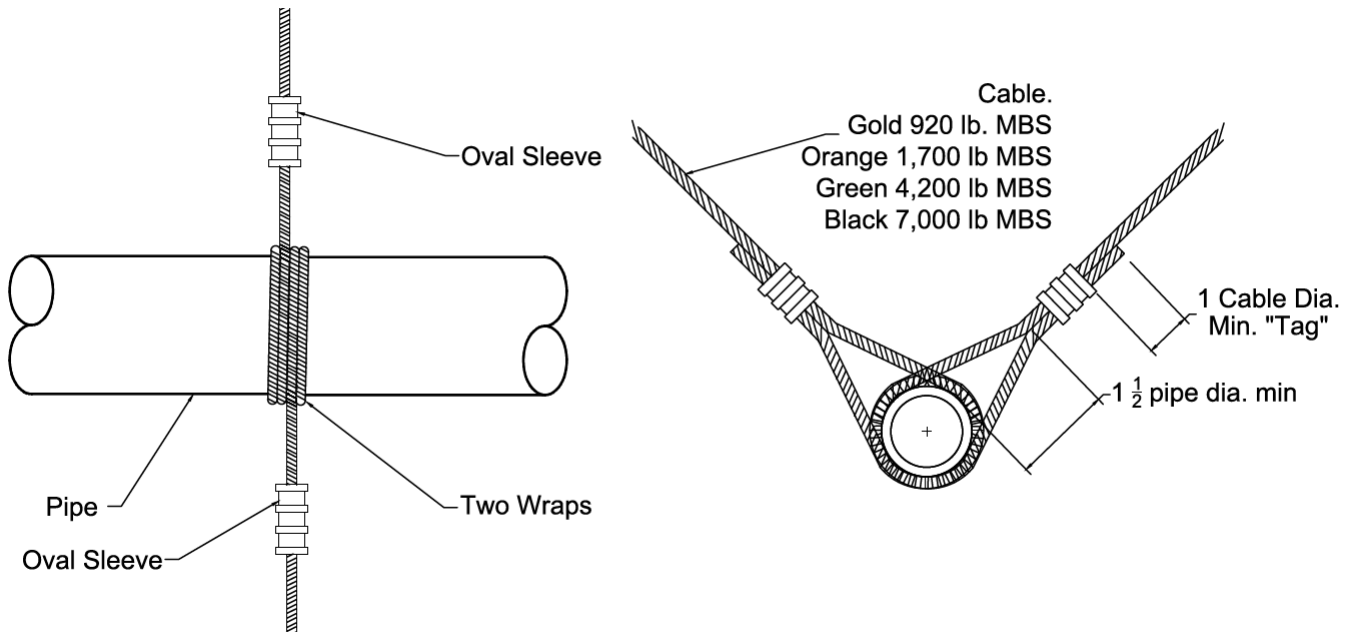

1. Slide oval sleeve onto end of cable. Slide sleeve up cable to allow working room.
2. Wrap cable around pipe twice. Form a simple knot on the second wrap to hold the cable in place.
3. Slide loose end of the cable into sleeve and pull cable to remove slack.
4. Crimp sleeve per Figure 1 below.
5. Repeat in opposite direction.

Figure 1

Size	Cable Color	Number of Crimps	Break Strength (lbs)	Working Load (lbs)
#GO3	Gold	2	920	418
#OR4	Orange	2	1,700	770
#GR6	Green	3	4,200	1,900
#BL8	Black	3	7,000	3,180

Longitudinal Brace

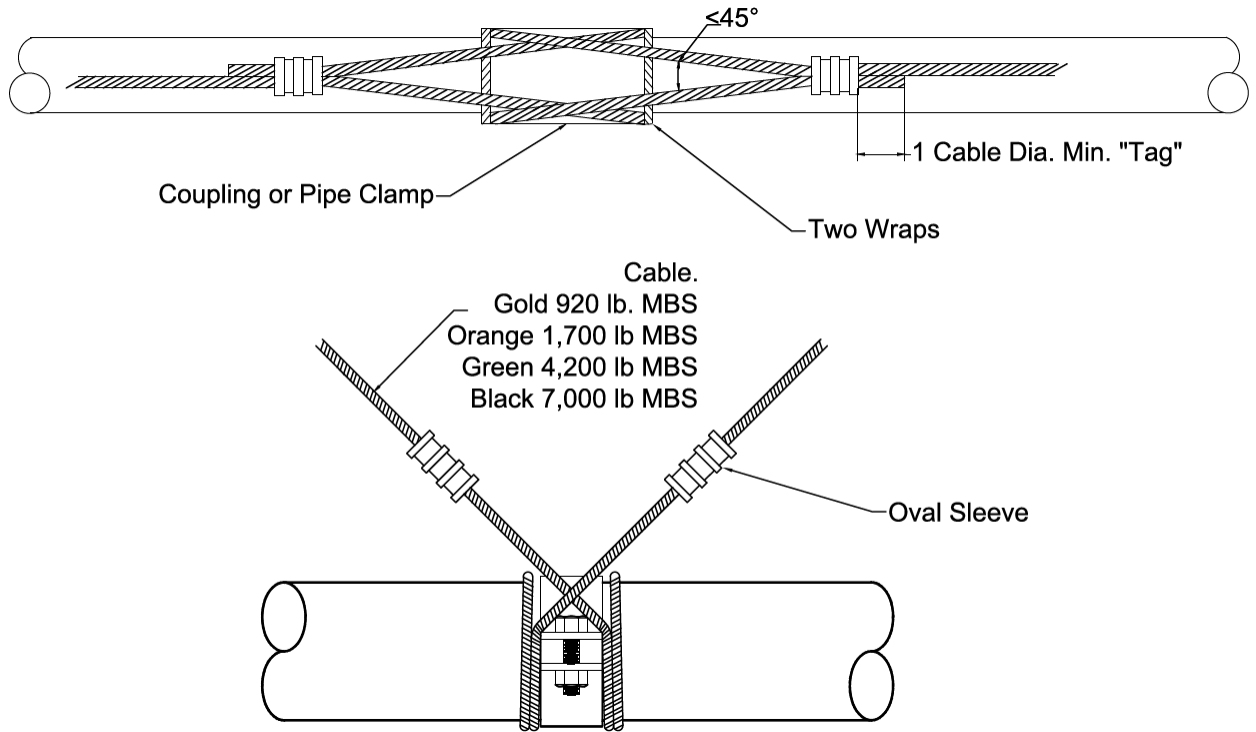

1. Slide oval sleeve onto end of cable. Slide sleeve up cable to allow working room.
2. Wrap cable around pipe twice. Form a simple knot on the second wrap to hold the cable in place. Be sure the wrap is on the far side of a pipe clamp or grooved coupling, and not on it.
3. Slide loose end of the cable into sleeve and pull cable to remove slack.
4. Crimp sleeve per Figure 1 below.
5. Repeat in opposite direction.

Figure 1

Size	Cable Color	Number of Crimps	Break Strength (lbs)	Working Load (lbs)
#GO3	Gold	2	920	418
#OR4	Orange	2	1,700	770
#GR6	Green	3	4,200	1,900
#BL8	Black	3	7,000	3,180

INSTRUCTIONS



4-Way Brace

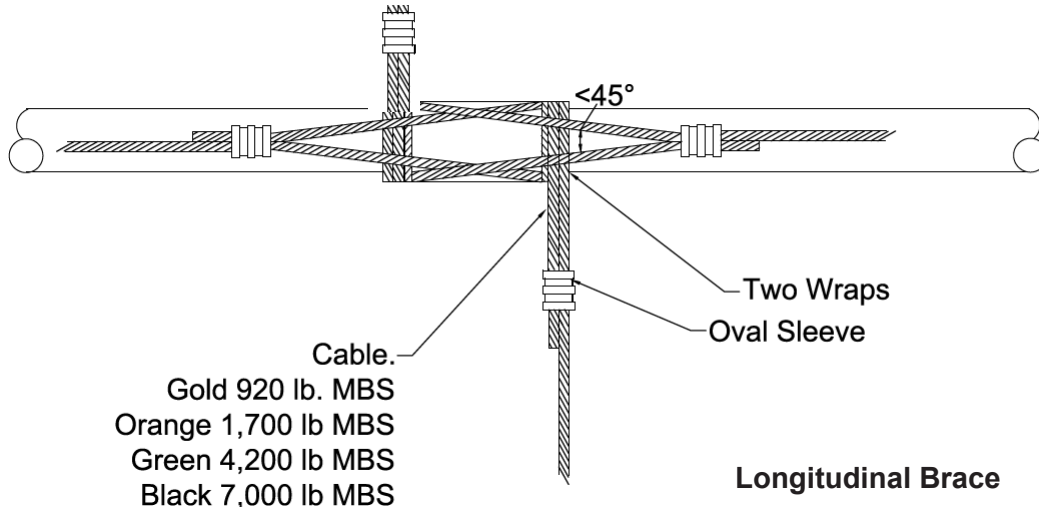

Lateral Brace

1. Slide oval sleeve onto end of cable. Slide sleeve up cable to allow working room.
2. Wrap cable around pipe twice. Form a simple knot on the second wrap to hold the cable in place.
3. Slide loose end of the cable into sleeve and pull cable to remove slack.
4. Crimp sleeve per Figure 1 below.
5. Repeat in opposite direction.

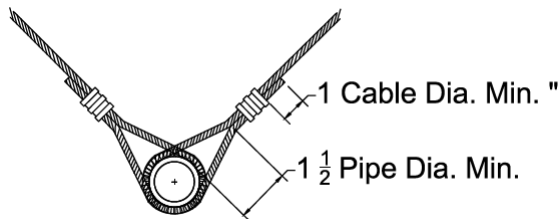

Longitudinal Brace

1. Slide oval sleeve onto end of cable. Slide sleeve up cable to allow working room.
2. Wrap cable around pipe twice. Form a simple knot on the second wrap to hold the cable in place. Be sure the wrap is on the far side of a pipe clamp or grooved coupling, and not on it.
3. Slide loose end of the cable into sleeve and pull cable to remove slack.
4. Crimp sleeve per Figure 1 below.
5. Repeat in opposite direction.

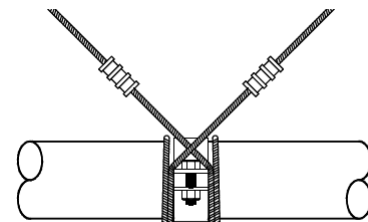

Figure 1

Size	Cable Color	Number of Crimps	Break Strength (lbs)	Working Load (lbs)
#GO3	Gold	2	920	418
#OR4	Orange	2	1,700	770
#GR6	Green	3	4,200	1,900
#BL8	Black	3	7,000	3,180

Splicing Instructions



1. Slide one end of the first cable through both sleeves on the same side of the oval sleeve.
2. Slide one end of the second cable through both sleeves on the opposite side of the oval sleeves
3. 1" min space and crimp the two oval sleeves as per Table 1.

Table 1

Size	Cable Color	Number of Crimps
#GO3	Gold	2
#OR4	Orange	2
#GR6	Green	3
#BL8	Black	3



INSTRUCTIONS

Load: Perpendicular to Structural Member

Angles: A (30°), B (45°), and C (60°)

Material: Through bolts in wood

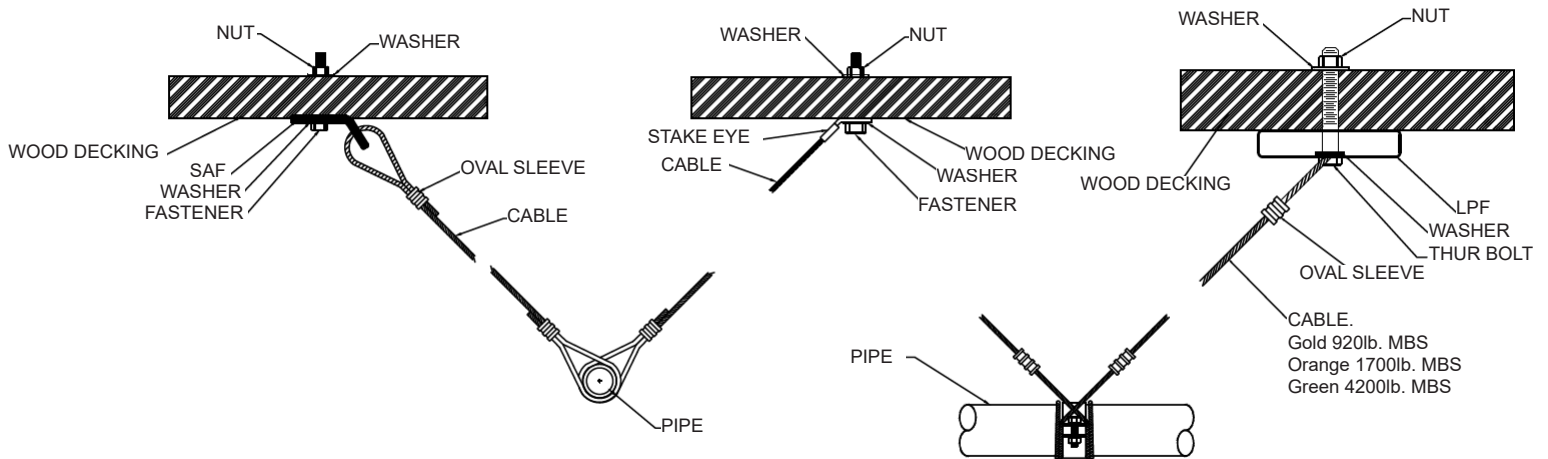

Bolt Length	1/2" Bolt Diameter			5/8" Bolt Diameter			3/4" Bolt Diameter		
	30° - 44°	45° - 59°	60° - 90°	30° - 44°	45° - 59°	60° - 90°	30° - 44°	45° - 59°	60° - 90°
1-1/2"	115 lbs.	165 lbs.	200 lbs.	135 lbs.	190 lbs.	235 lbs.	155 lbs.	220 lbs.	270 lbs.
2-1/2"	140 lbs.	200 lbs.	240 lbs.	160 lbs.	225 lbs.	280 lbs.	180 lbs.	255 lbs.	310 lbs.
3-1/2"	175 lbs.	250 lbs.	305 lbs.	200 lbs.	285 lbs.	345 lbs.	220 lbs.	310 lbs.	380 lbs.
5-1/2"	N/A	N/A	N/A	280 lbs.	395 lbs.	485 lbs.	310 lbs.	440 lbs.	535 lbs.

Above listed values based on wood with a specific gravity of 0.35. Values for other woods can be obtained by multiplying above values by factors listed in Figure 1.

Figure 1

Specific Gravity of Wood	Multiplier
0.36 - 0.49	1.17
0.50 - 0.65	1.25
0.66 - 0.73	1.50



Load: Perpendicular to Structural Member

Angles: A (30°), B (45°), and C (60°)

Material: Lag bolts in wood

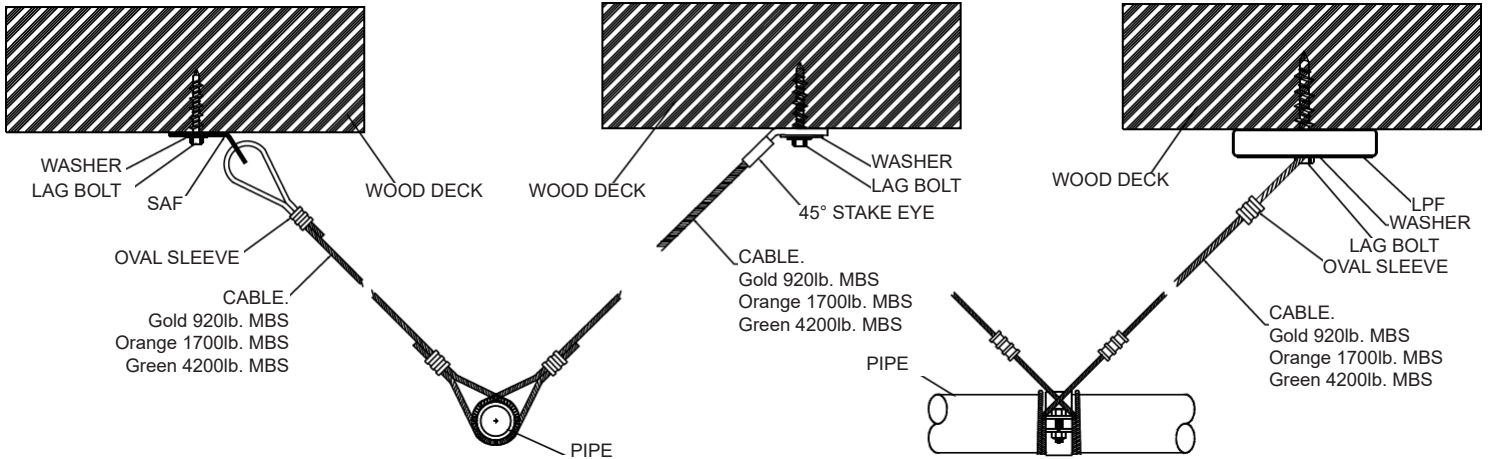

Lag Length	3/8" Lag Diameter			1/2" Lag Diameter			5/8" Lag Diameter		
	30° - 44°	45° - 59°	60° - 90°	30° - 44°	45° - 59°	60° - 90°	30° - 44°	45° - 59°	60° - 90°
3-1/2"	165 lbs.	190 lbs.	200 lbs.						
4-1/2"	180 lbs.	200 lbs.	200 lbs.	300 lbs.	355 lbs.	380 lbs.			
5-1/2"	190 lbs.	200 lbs.	200 lbs.	320 lbs.	370 lbs.	380 lbs.	435 lbs.	525 lbs.	555 lbs.
6-1/2"	195 lbs.	205 lbs.	200 lbs.	340 lbs.	375 lbs.	380 lbs.	465 lbs.	540 lbs.	555 lbs.

Above listed values based on wood with a specific gravity of 0.35. Values for other woods can be obtained by multiplying above values by factors listed in Figure 1.

Figure 1

Specific Gravity of Wood	Multiplier
0.36 - 0.49	1.17
0.50 - 0.65	1.25
0.66 - 0.73	1.50



INSTRUCTIONS

Load: Perpendicular to Structural Member

Angles: A (30°), B (45°), and C (60°)

Material: Wedge anchors in 3,000 PSI lightweight cracked concrete on metal decking

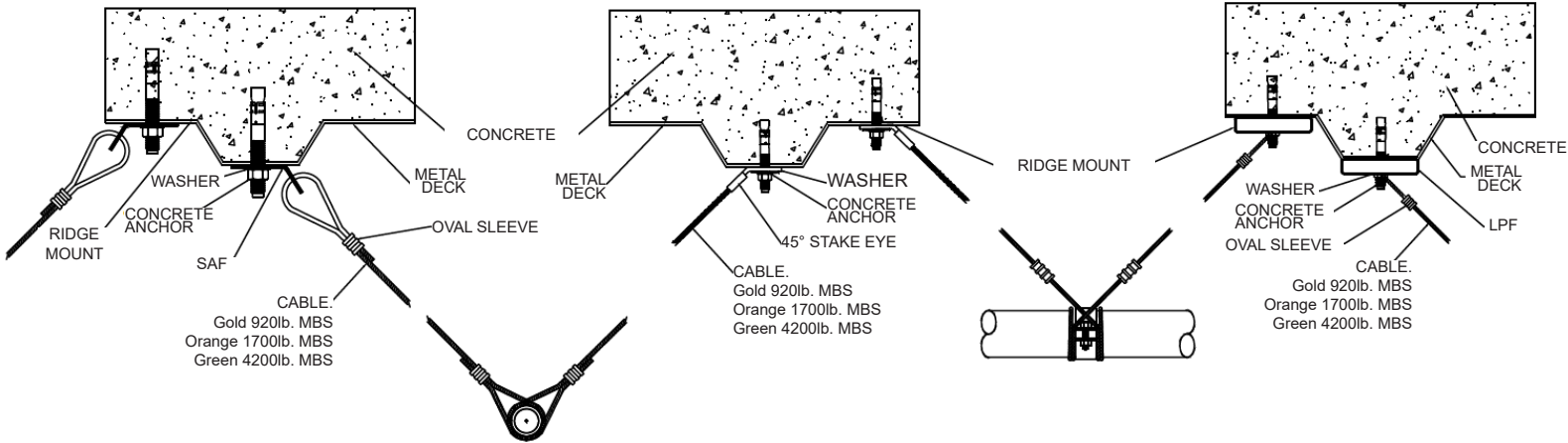

Maximum Load for Wedge Anchors in 3,000 psi (207 bar) Lightweight Cracked Concrete on Metal Deck

Fastener Diameter	Fastener Embedment	LPF			SAF (All)			Stake Eye		
		30°-44°	45°-59°	60°-90°	30°-44°	45°-59°	60°-90°	30°-44°	45°-59°	60°-90°
3/8"	4-3/8"	117 lbs.	184 lbs.	246 lbs.	69 lbs.	127 lbs.	196 lbs.	69 lbs.	127 lbs.	196 lbs.
1/2"	7"	164 lbs.	257 lbs.	344 lbs.	97 lbs.	178 lbs.	274 lbs.	97 lbs.	178 lbs.	274 lbs.
5/8"	9-1/2"	214 lbs.	326 lbs.	424 lbs.	133 lbs.	232 lbs.	346 lbs.	N/A	N/A	N/A



Load: Perpendicular to Structural Member

Angles: A (30°), B (45°), and C (60°)

Material: Wedge anchors in 3,000 PSI normal-weight cracked concrete

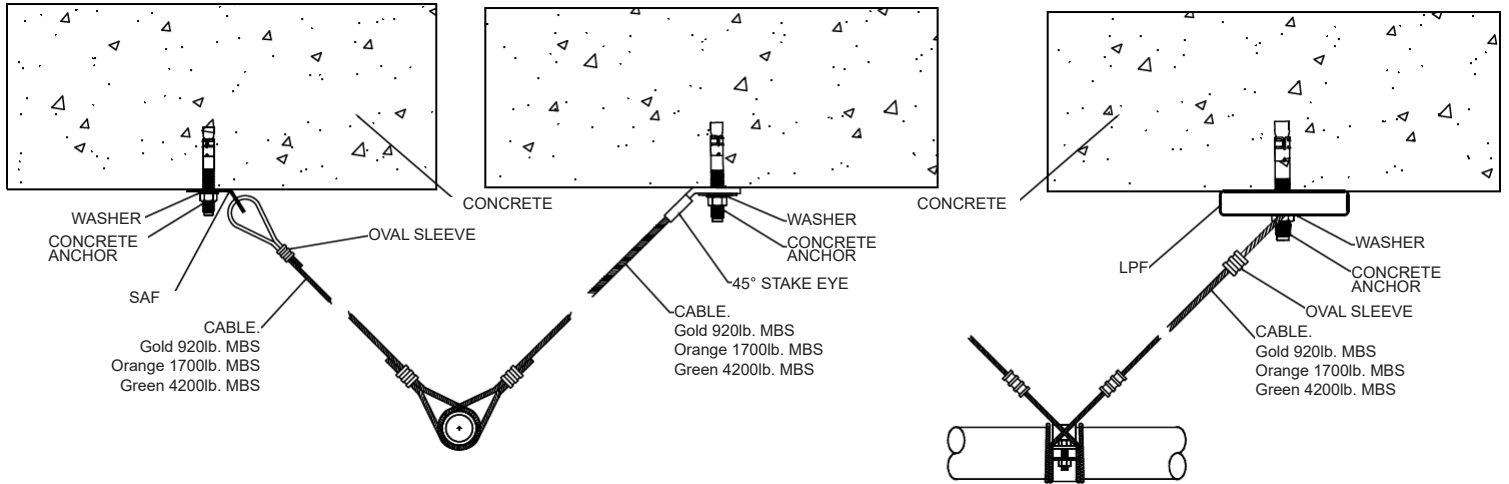

Maximum Load for Wedge Anchors in 3,000 psi (207 bar) Normal-Weight Cracked Concrete

Fastener Diameter	Fastener Embedment	LPF			SAF (All)			Stake Eye		
		30°-44°	45°-59°	60°-90°	30°-44°	45°-59°	60°-90°	30°-44°	45°-59°	60°-90°
3/8"	2"	171 lbs.	240 lbs.	292 lbs.	116 lbs.	183 lbs.	252 lbs.	116 lbs.	183 lbs.	252 lbs.
1/2"	3-5/8"	412 lbs.	567 lbs.	682 lbs.	282 lbs.	438 lbs.	592 lbs.	282 lbs.	438 lbs.	592 lbs.
5/8"	3-7/8"	480 lbs.	668 lbs.	809 lbs.	327 lbs.	512 lbs.	699 lbs.	N/A	N/A	N/A
3/4"	4-1/8"	545 lbs.	780 lbs.	965 lbs.	363 lbs.	584 lbs.	819 lbs.	N/A	N/A	N/A



INSTRUCTIONS

Load: Perpendicular to Structural Member

Angles: A (30°), B (45°), and C (60°)

Material: Undercut anchors in 3,000 PSI normal-weight cracked concrete

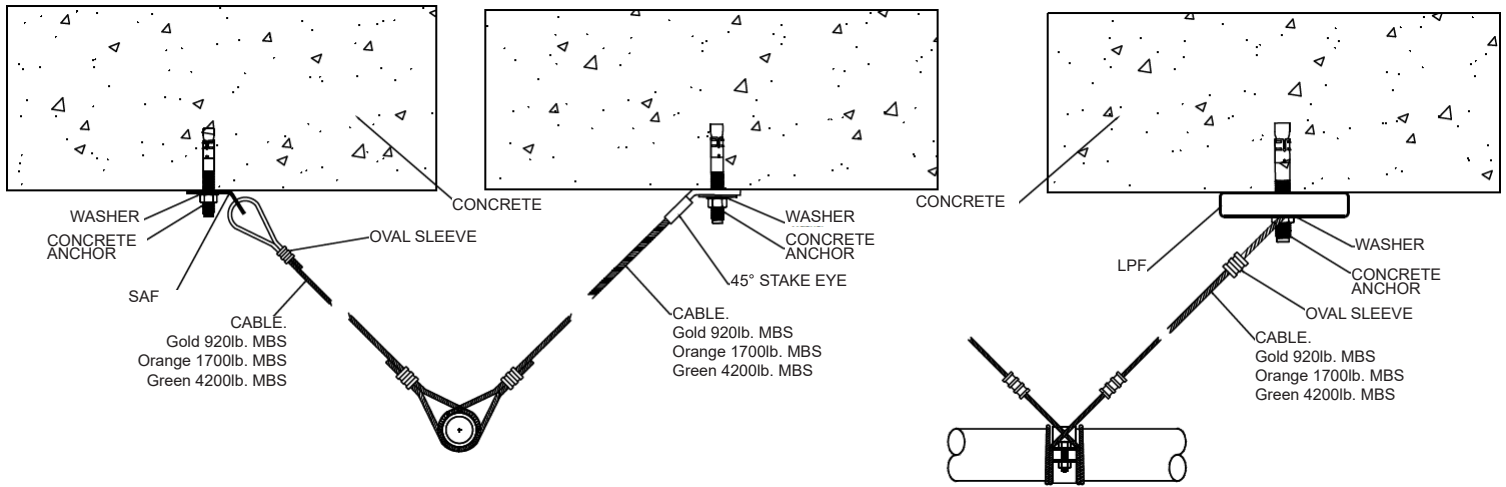

Maximum Load for Undercut Anchors in 3,000 psi (207 bar) Normal-Weight Cracked

Fastener Diameter	Fastener Embedment	LPF			SAF (All)			Stake Eye		
		30°-44°	45°-59°	60°-90°	30°-44°	45°-59°	60°-90°	30°-44°	45°-59°	60°-90°
3/8"	4-3/8"	501 lbs.	638 lbs.	726 lbs.	368 lbs.	526 lbs.	658 lbs.	368 lbs.	526 lbs.	658 lbs.
1/2"	7"	700 lbs.	911 lbs.	1,051 lbs.	505 lbs.	738 lbs.	942 lbs.	505 lbs.	738 lbs.	942 lbs.
5/8"	9-1/2"	1,106 lbs.	1,535 lbs.	1,855 lbs.	754 lbs.	1,179 lbs.	1,604 lbs.	N/A	N/A	N/A
3/4"	12"	1,701 lbs.	2,402 lbs.	2,946 lbs.	1,143 lbs.	1,819 lbs.	2,520 lbs.	N/A	N/A	N/A



Load: Perpendicular to Structural Member

Angles: A (30°), B (45°), and C (60°)

Material: Wedge anchors in 3,000 PSI lightweight cracked concrete

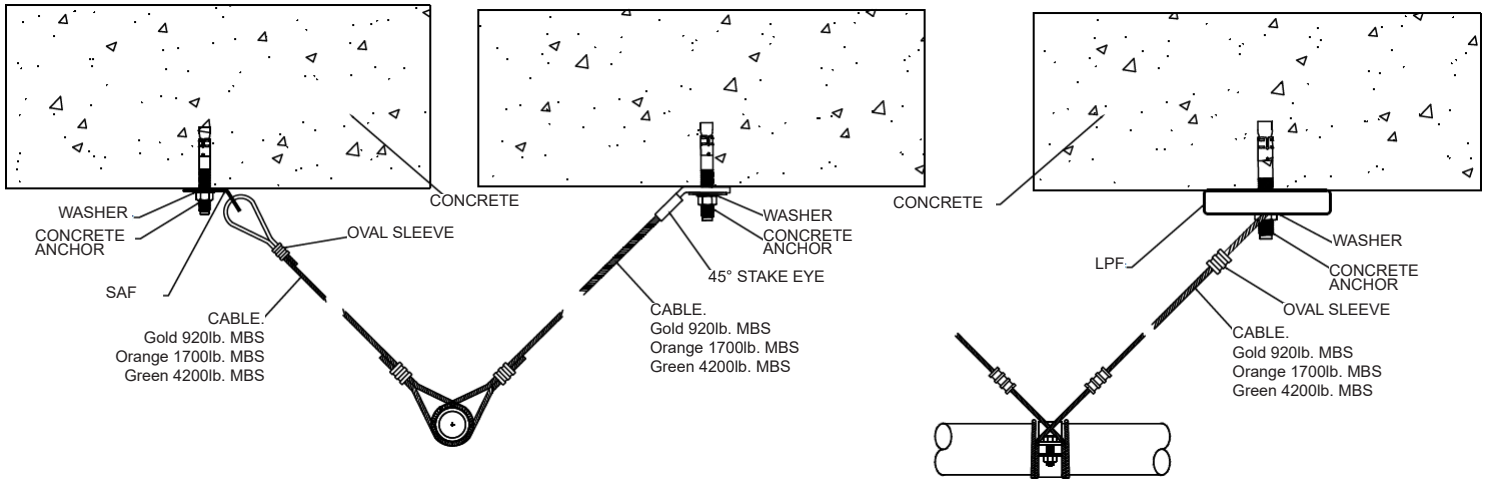

Maximum Load for Wedge Anchors in 3,000 psi (207 bar) Lightweight Cracked Concrete

Fastener Diameter	Fastener Embedment	LPF			SAF (All)			Stake Eye		
		30°-44°	45°-59°	60°-90°	30°-44°	45°-59°	60°-90°	30°-44°	45°-59°	60°-90°
3/8"	2"	102 lbs.	144 lbs.	175 lbs.	69 lbs.	109 lbs.	150 lbs.	69 lbs.	109 lbs.	150 lbs.
1/2"	2-3/8"	140 lbs.	196 lbs.	238 lbs.	94 lbs.	149 lbs.	205 lbs.	94 lbs.	149 lbs.	205 lbs.
5/8"	3-1/4"	222 lbs.	308 lbs.	372 lbs.	151 lbs.	237 lbs.	322 lbs.	N/A	N/A	N/A
3/4"	4-1/8"	327 lbs.	469 lbs.	580 lbs.	217 lbs.	351 lbs.	492 lbs.	N/A	N/A	N/A



INSTRUCTIONS

Load: Perpendicular to Structural Member

Angles: A (30°), B (45°), and C (60°)

Material: Wedge anchors in 4,000 PSI normal-weight cracked concrete

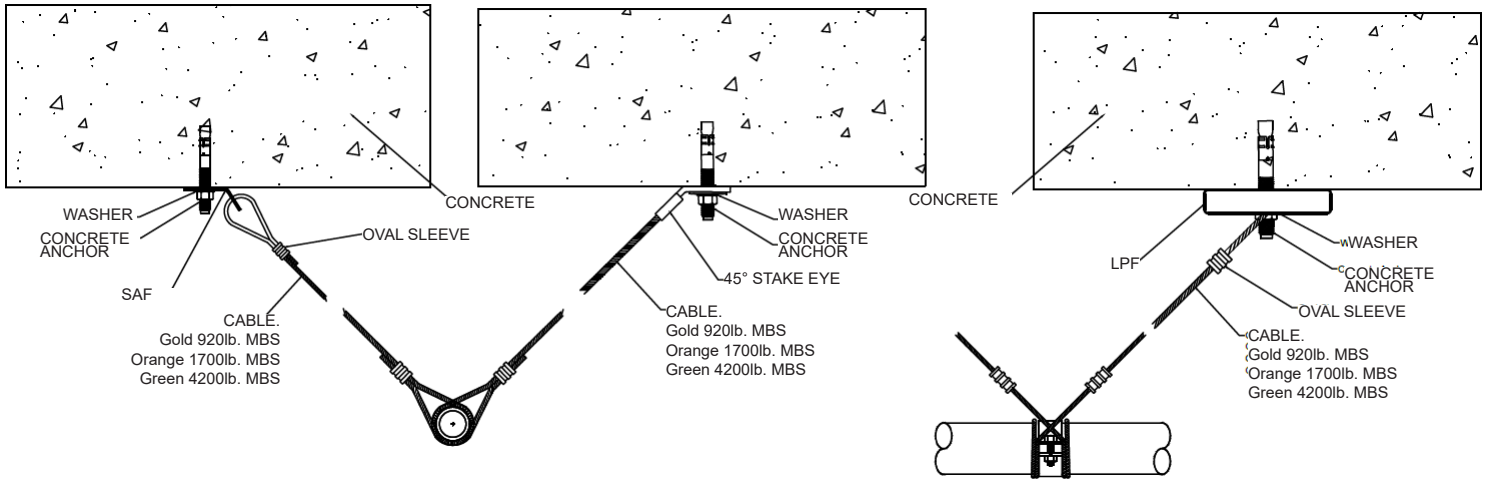

Maximum Load for Wedge Anchors in 4,000 psi (267 bar) Normal-Weight Cracked Concrete

Fastener Diameter	Fastener Embedment	LPF			SAF (All)			Stake Eye		
		30°-44°	45°-59°	60°-90°	30°-44°	45°-59°	60°-90°	30°-44°	45°-59°	60°-90°
3/8"	2"	200 lbs.	282 lbs.	344 lbs.	135 lbs.	214 lbs.	295 lbs.	135 lbs.	214 lbs.	295 lbs.
1/2"	3-5/8"	430 lbs.	607 lbs.	742 lbs.	289 lbs.	460 lbs.	636 lbs.	289 lbs.	460 lbs.	636 lbs.
5/8"	3-7/8"	532 lbs.	729 lbs.	872 lbs.	367 lbs.	566 lbs.	760 lbs.	N/A	N/A	N/A
3/4"	4-1/8"	630 lbs.	903 lbs.	1,117 lbs.	419 lbs.	676 lbs.	948 lbs.	N/A	N/A	N/A



Load: Perpendicular to Structural Member

Angles: A (30°), B (45°), and C (60°)

Material: Wedge anchors in 6,000 PSI normal-weight cracked concrete

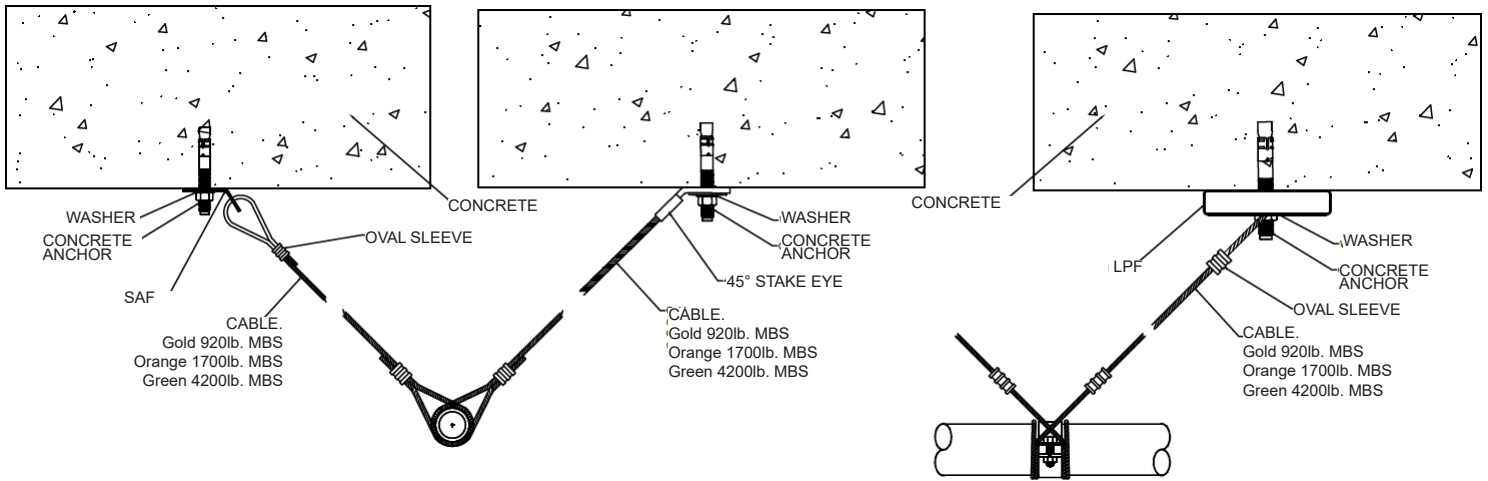

Maximum Load for Wedge Anchors in 6,000 psi (414 bar) Normal-Weight Cracked Concrete

Fastener Diameter	Fastener Embedment	LPF			SAF (All)			Stake Eye		
		30°-44°	45°-59°	60°-90°	30°-44°	45°-59°	60°-90°	30°-44°	45°-59°	60°-90°
3/8"	2-1/4"	254 lbs.	354 lbs.	428 lbs.	172 lbs.	271 lbs.	370 lbs.	172 lbs.	271 lbs.	370 lbs.
1/2"	3-5/8"	527 lbs.	744 lbs.	910 lbs.	355 lbs.	564 lbs.	780 lbs.	355 lbs.	564 lbs.	780 lbs.
5/8"	3-7/8"	652 lbs.	893 lbs.	1,069 lbs.	450 lbs.	694 lbs.	932 lbs.	N/A	N/A	N/A
3/4"	4-1/8"	722 lbs.	1,106 lbs.	1,369 lbs.	514 lbs.	828 lbs.	1,162 lbs.	N/A	N/A	N/A



INSTRUCTIONS

Load: Perpendicular to Structural Member

Angles: A (30°), B (45°), and C (60°)

Material: Connections to steel

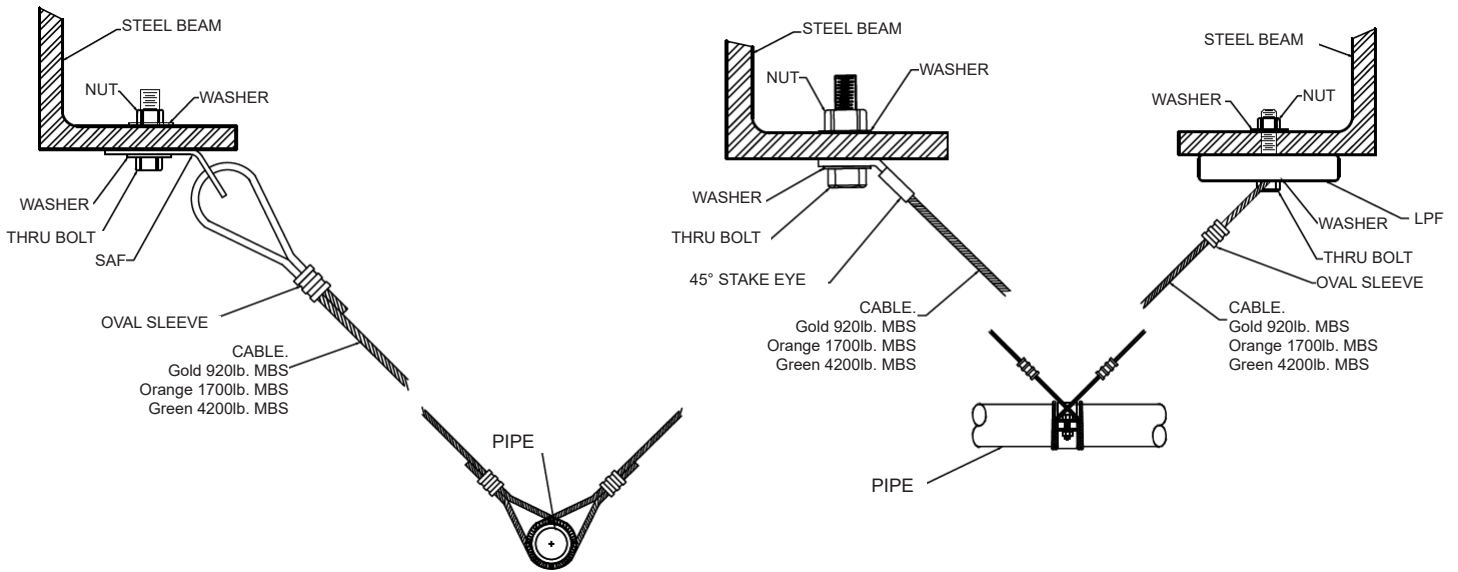

Diameter	30° - 44°	45° - 59°	60° - 90°
1/4"	400 lbs.	500 lbs.	600 lbs.
3/8"	900 lbs.	1,200 lbs.	1,400 lbs.
1/2"	1,600 lbs.	2,050 lbs.	2,550 lbs.
5/8"	2,500 lbs.	3,300 lbs.	3,950 lbs.



Load: Perpendicular to Structural Member

Angles: D (30°), E (45°), and F (60°)

Material: Through bolts in wood

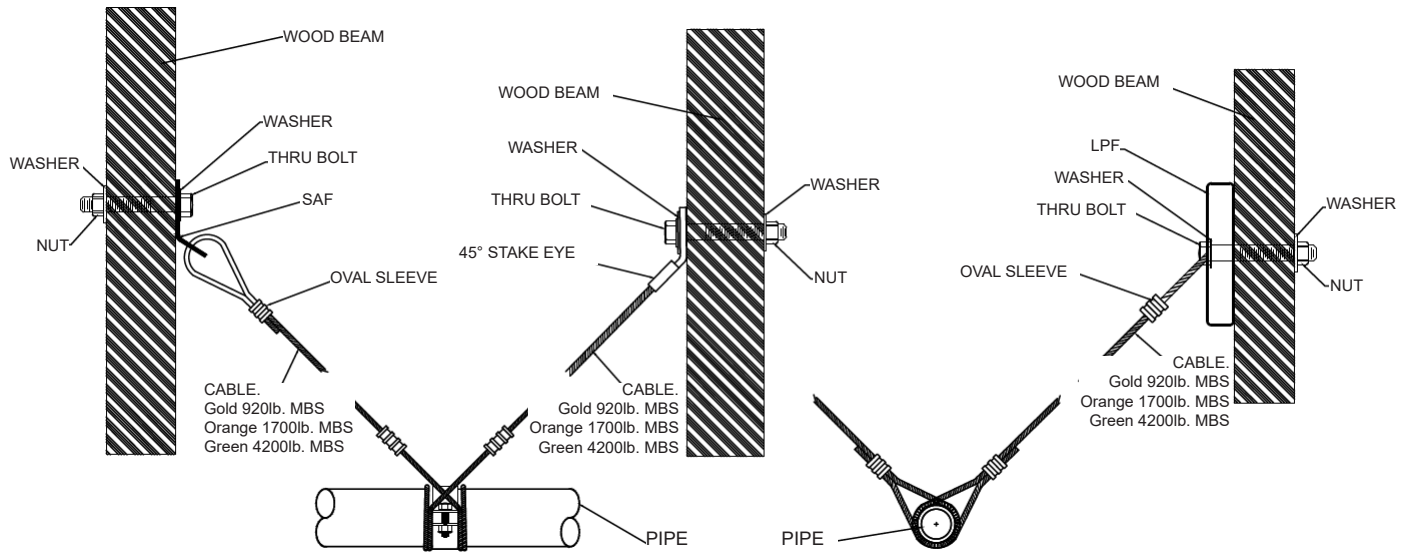

Bolt Length	1/2" Bolt Diameter			5/8" Bolt Diameter			3/4" Bolt Diameter		
	30° - 44°	45° - 59°	60° - 90°	30° - 44°	45° - 59°	60° - 90°	30° - 44°	45° - 59°	60° - 90°
1-1/2"	135 lbs.	230 lbs.	395 lbs.	155 lbs.	270 lbs.	460 lbs.	180 lbs.	310 lbs.	530 lbs.
2-1/2"	160 lbs.	280 lbs.	480 lbs.	185 lbs.	320 lbs.	550 lbs.	205 lbs.	360 lbs.	615 lbs.
3-1/2"	200 lbs.	350 lbs.	600 lbs.	230 lbs.	400 lbs.	685 lbs.	255 lbs.	440 lbs.	755 lbs.
5-1/2"	N/A	N/A	N/A	325 lbs.	560 lbs.	960 lbs.	360 lbs.	620 lbs.	1,065 lbs.

Above listed values based on wood with a specific gravity of 0.35. Values for other woods can be obtained by multiplying above values by factors listed in Figure 1.

Figure 1

Specific Gravity of Wood	Multiplier
0.36 - 0.49	1.17
0.50 - 0.65	1.25
0.66 - 0.73	1.50



INSTRUCTIONS

Load: Perpendicular to Structural Member

Angles: D (30°), E (45°), and F (60°)

Material: Lag bolts in wood

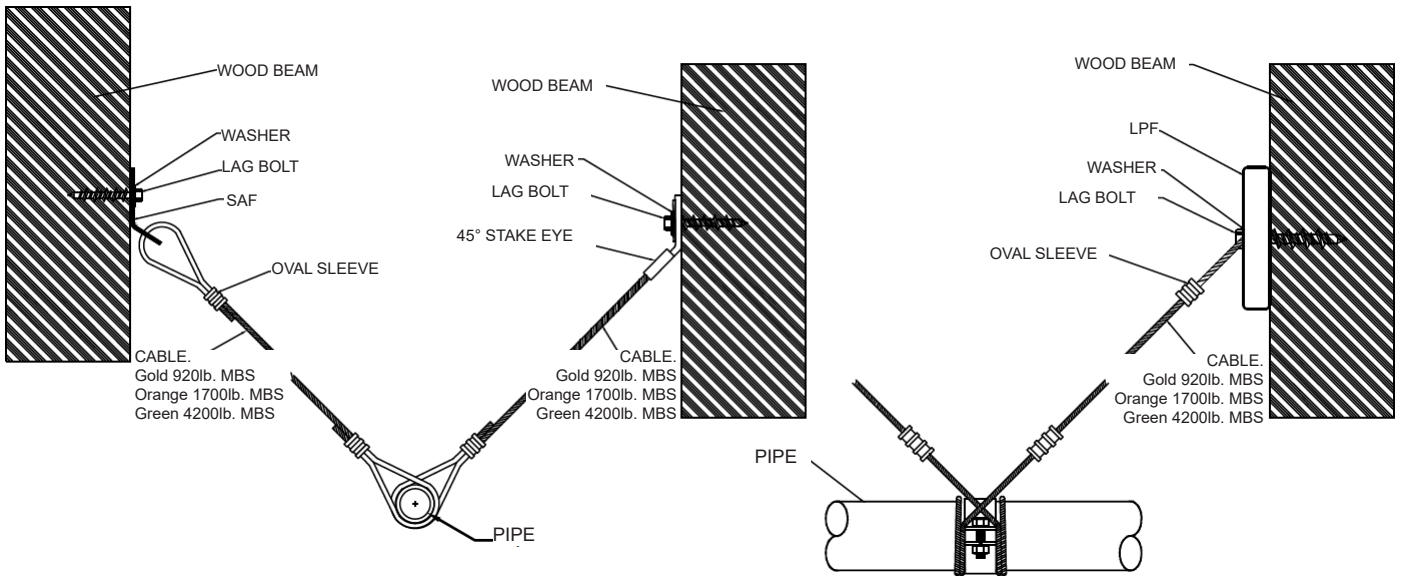

Lag Length	3/8" Lag Diameter			1/2" Lag Diameter			5/8" Lag Diameter		
	30° - 44°	45° - 59°	60° - 90°	30° - 44°	45° - 59°	60° - 90°	30° - 44°	45° - 59°	60° - 90°
3-1/2"	170 lbs.	220 lbs.	310 lbs.						
4-1/2"	175 lbs.	235 lbs.	350 lbs.	315 lbs.	400 lbs.	550 lbs.			
5-1/2"	175 lbs.	245 lbs.	380 lbs.	320 lbs.	420 lbs.	610 lbs.	425 lbs.	550 lbs.	775 lbs.
6-1/2"	175 lbs.	250 lbs.	400 lbs.	325 lbs.	435 lbs.	650 lbs.	430 lbs.	570 lbs.	840 lbs.

Above listed values based on wood with a specific gravity of 0.35. Values for other woods can be obtained by multiplying above values by factors listed in Figure 1.

Figure 1

Specific Gravity of Wood	Multiplier
0.36 - 0.49	1.17
0.50 - 0.65	1.25
0.66 - 0.73	1.50



Load: Perpendicular to Structural Member

Angles: D (30°), E (45°), and F (60°)

Material: Wedge anchors in 3,000 PSI normal-weight cracked concrete

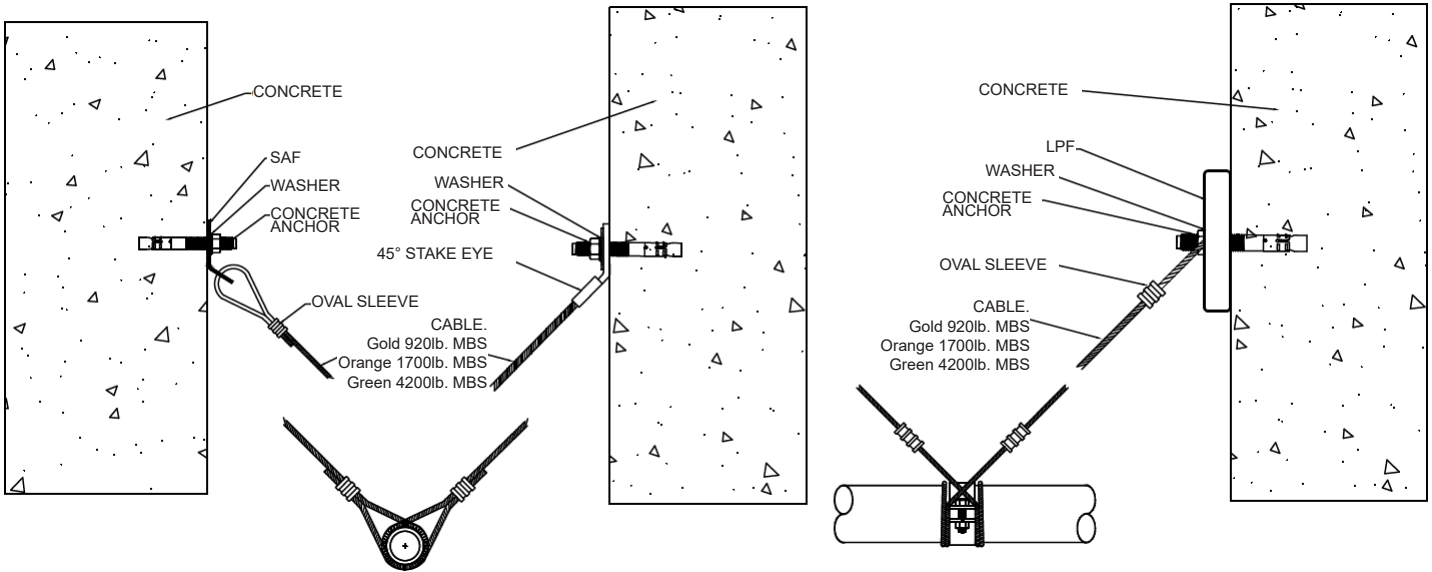

Maximum Load for Wedge Anchors in 3,000 psi (207 bar) Normal-Weight Cracked Concrete

Fastener Diameter	Fastener Embedment	LPF			SAF (All)			Stake Eye		
		30°-44°	45°-59°	60°-90°	30°-44°	45°-59°	60°-90°	30°-44°	45°-59°	60°-90°
3/8"	2"	169 lbs.	240 lbs.	307 lbs.	146 lbs.	183 lbs.	203 lbs.	146 lbs.	183 lbs.	203 lbs.
1/2"	3-5/8"	394 lbs.	567 lbs.	735 lbs.	344 lbs.	438 lbs.	493 lbs.	344 lbs.	438 lbs.	493 lbs.
5/8"	3-7/8"	468 lbs.	668 lbs.	859 lbs.	406 lbs.	512 lbs.	571 lbs.	N/A	N/A	N/A
3/4"	4-1/8"	559 lbs.	780 lbs.	976 lbs.	477 lbs.	584 lbs.	634 lbs.	N/A	N/A	N/A



INSTRUCTIONS

Load: Perpendicular to Structural Member

Angles: D (30°), E (45°), and F (60°)

Material: Undercut anchors in 3,000 PSI normal-weight cracked concrete

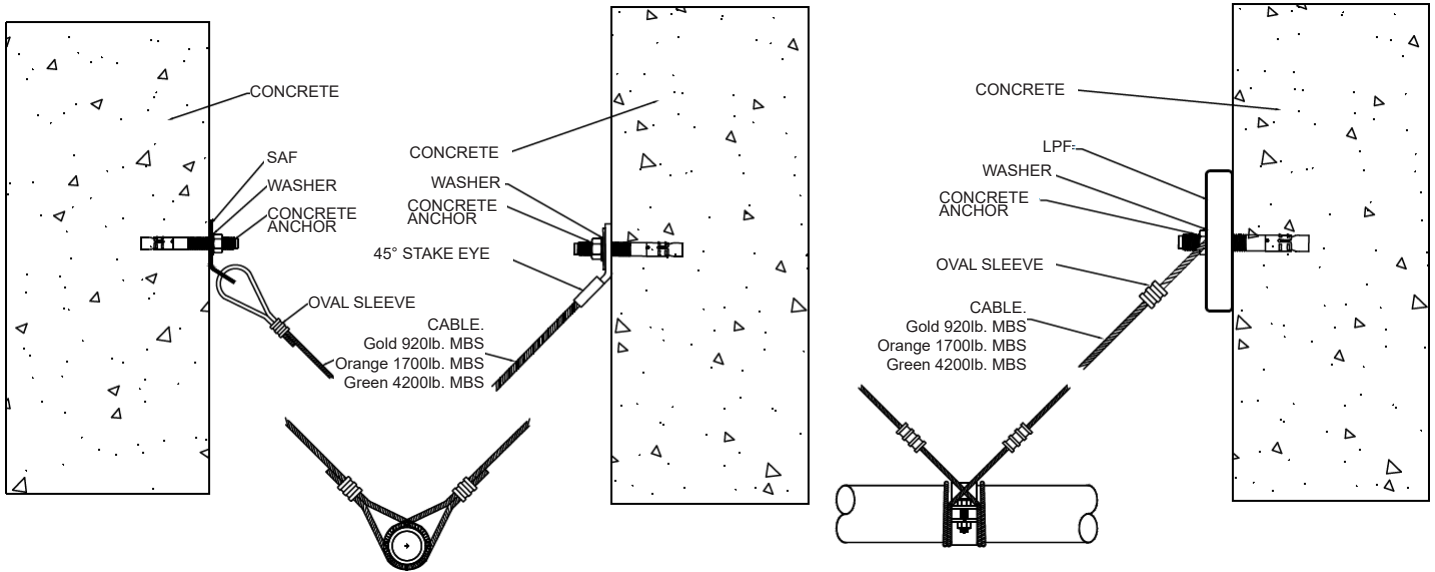

Maximum Load for Undercut Anchors in 3,000 psi (207 bar) Normal-Weight Cracked Concrete

Fastener Diameter	Fastener Embedment	LPF			SAF (All)			Stake Eye		
		30°-44°	45°-59°	60°-90°	30°-44°	45°-59°	60°-90°	30°-44°	45°-59°	60°-90°
3/8"	4-3/8"	420 lbs.	638 lbs.	889 lbs.	381 lbs.	526 lbs.	643 lbs.	381 lbs.	526 lbs.	643 lbs.
1/2"	7"	608 lbs.	911 lbs.	1,245 lbs.	547 lbs.	738 lbs.	882 lbs.	547 lbs.	738 lbs.	882 lbs.
5/8"	9-1/2"	1,071 lbs.	1,535 lbs.	1,975 lbs.	933 lbs.	1,179 lbs.	1,318 lbs.	N/A	N/A	N/A
3/4"	12"	1,707 lbs.	2,404 lbs.	3,041 lbs.	1,468 lbs.	1,819 lbs.	1,969 lbs.	N/A	N/A	N/A



Load: Perpendicular to Structural Member

Angles: D (30°), E (45°), and F (60°)

Material: Wedge anchors in 3,000 PSI lightweight cracked concrete

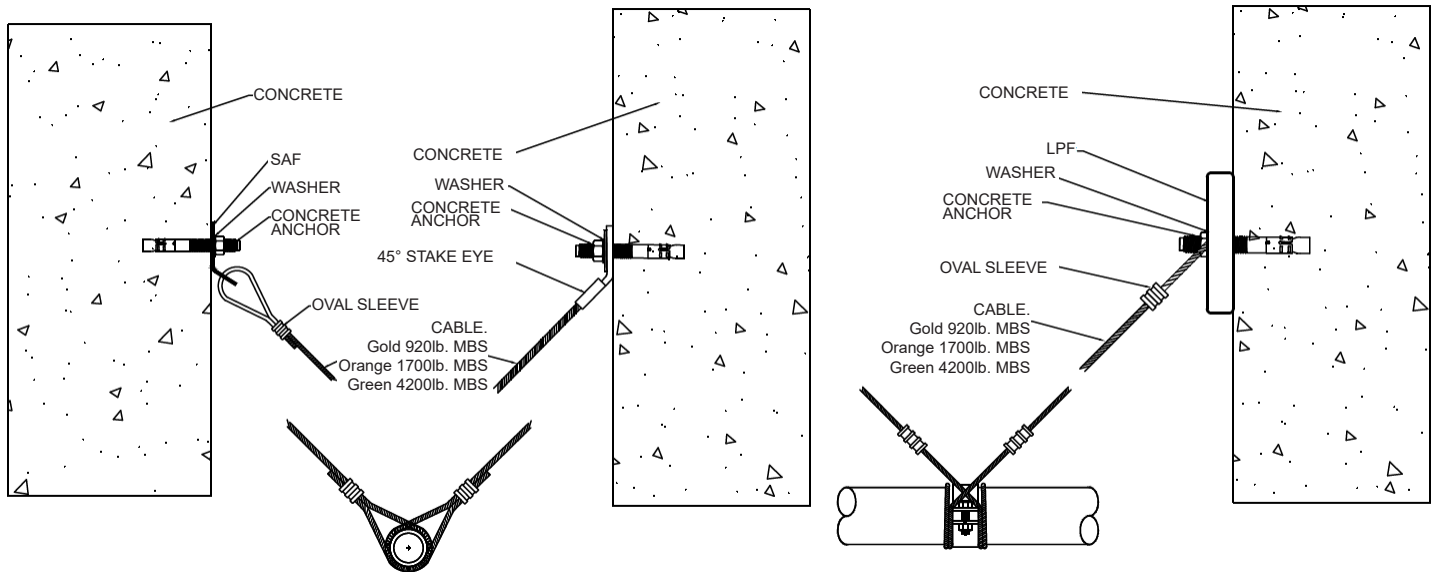

Maximum Load for Undercut Anchors in 3,000 psi (207 bar) Lightweight Cracked Concrete

Fastener Diameter	Fastener Embedment	LPF			SAF (All)			Stake Eye		
		30°-44°	45°-59°	60°-90°	30°-44°	45°-59°	60°-90°	30°-44°	45°-59°	60°-90°
3/8"	2"	101 lbs.	144 lbs.	184 lbs.	87 lbs.	109 lbs.	121 lbs.	87 lbs.	109 lbs.	121 lbs.
1/2"	2-3/8"	137 lbs.	196 lbs.	251 lbs.	119 lbs.	149 lbs.	166 lbs.	119 lbs.	149 lbs.	166 lbs.
5/8"	3-1/4"	215 lbs.	308 lbs.	397 lbs.	187 lbs.	237 lbs.	265 lbs.	N/A	N/A	N/A
3/4"	4-1/8"	336 lbs.	469 lbs.	586 lbs.	286 lbs.	351 lbs.	380 lbs.	N/A	N/A	N/A



INSTRUCTIONS

Load: Perpendicular to Structural Member

Angles: D (30°), E (45°), and F (60°)

Material: Wedge anchors in 4,000 PSI normal-weight cracked concrete

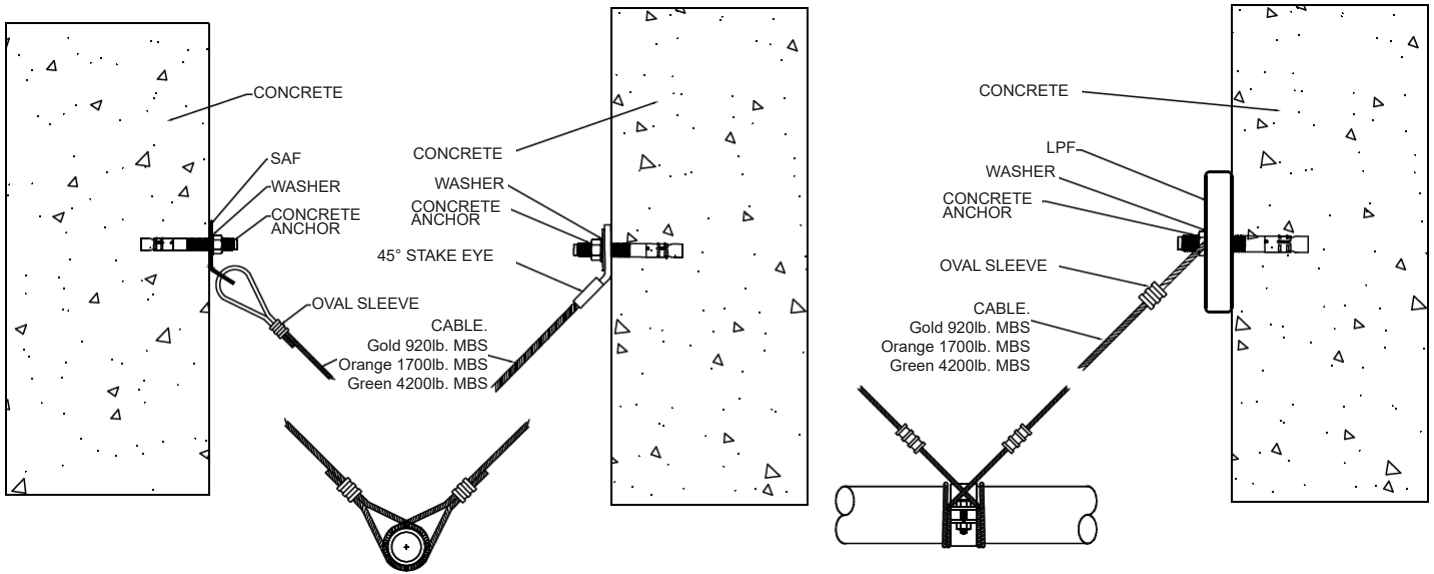

Maximum Load for Wedge Anchors in 4,000 psi (276 bar) Normal-Weight Cracked Concrete

Fastener Diameter	Fastener Embedment	LPF			SAF (All)			Stake Eye		
		30°-44°	45°-59°	60°-90°	30°-44°	45°-59°	60°-90°	30°-44°	45°-59°	60°-90°
3/8"	2"	199 lbs.	282 lbs.	359 lbs.	171 lbs.	214 lbs.	236 lbs.	171 lbs.	214 lbs.	236 lbs.
1/2"	3-5/8"	430 lbs.	607 lbs.	770 lbs.	370 lbs.	460 lbs.	506 lbs.	370 lbs.	460 lbs.	506 lbs.
5/8"	3-7/8"	505 lbs.	729 lbs.	950 lbs.	442 lbs.	566 lbs.	642 lbs.	N/A	N/A	N/A
3/4"	4-1/8"	647 lbs.	903 lbs.	1,129 lbs.	552 lbs.	676 lbs.	733 lbs.	N/A	N/A	N/A



Load: Perpendicular to Structural Member

Angles: D (30°), E (45°), and F (60°)

Material: Wedge anchors in 6,000 PSI normal-weight cracked concrete

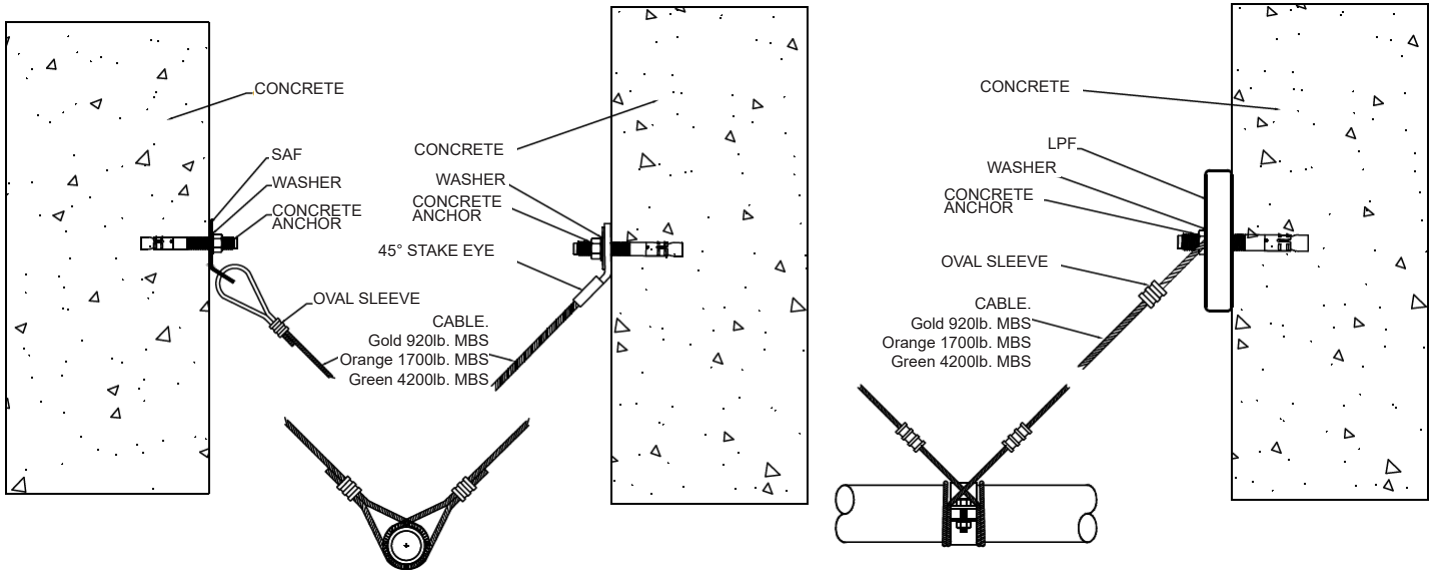

Maximum Load for Wedge Anchors in 6,000 psi (414 bar) Normal-Weight Cracked Concrete

Fastener Diameter	Fastener Embedment	LPF			SAF (All)			Stake Eye		
		30°-44°	45°-59°	60°-90°	30°-44°	45°-59°	60°-90°	30°-44°	45°-59°	60°-90°
3/8"	2-1/4"	199 lbs.	354 lbs.	585 lbs.	215 lbs.	271 lbs.	302 lbs.	215 lbs.	271 lbs.	302 lbs.
1/2"	3-5/8"	418 lbs.	744 lbs.	1,227 lbs.	453 lbs.	564 lbs.	621 lbs.	453 lbs.	564 lbs.	621 lbs.
5/8"	3-7/8"	504 lbs.	893 lbs.	1,481 lbs.	542 lbs.	694 lbs.	786 lbs.	N/A	N/A	N/A
3/4"	4-1/8"	622 lbs.	1,106 lbs.	1,816 lbs.	676 lbs.	828 lbs.	898 lbs.	N/A	N/A	N/A



INSTRUCTIONS

Load: Perpendicular to Structural Member

Angles: D (30°), E (45°), and F (60°)

Material: Connections to steel

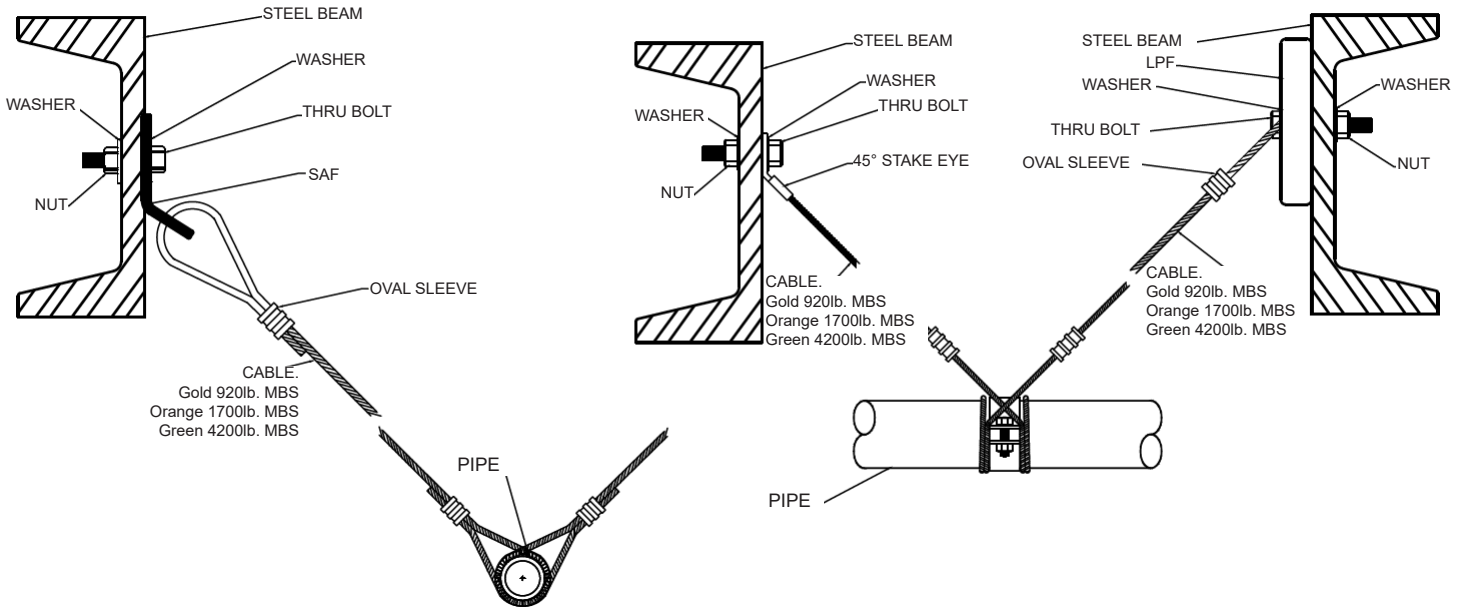

Diameter	30° - 44°	45° - 59°	60° - 90°
1/4"	300 lbs.	500 lbs.	650 lbs.
3/8"	800 lbs.	1,200 lbs.	1,550 lbs.
1/2"	1,450 lbs.	2,050 lbs.	2,850 lbs.
5/8"	2,250 lbs.	3,300 lbs.	4,400 lbs.



Load: Parallel to Structural Member

Angles: G (30°), H (45°), and I (60°)

Material: Through bolts in wood

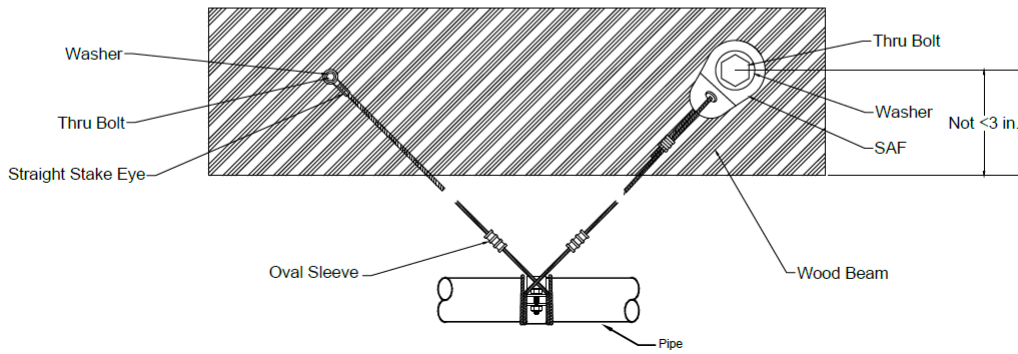
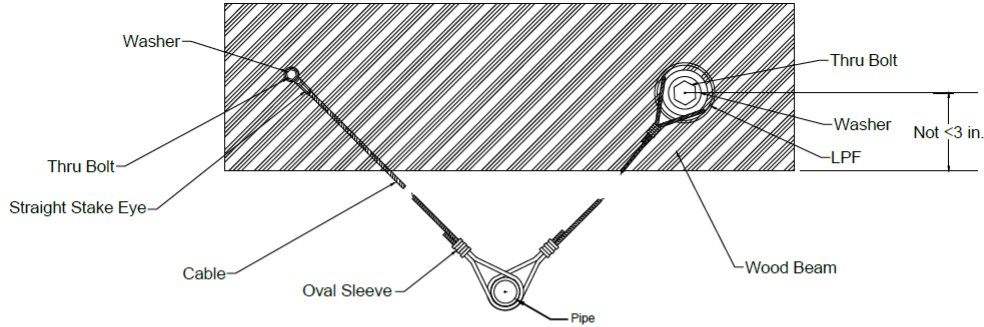

Bolt Length	1/2" Bolt Diameter			5/8" Bolt Diameter			3/4" Bolt Diameter		
	30° - 44°	45° - 59°	60° - 90°	30° - 44°	45° - 59°	60° - 90°	30° - 44°	45° - 59°	60° - 90°
1-1/2"	130 lbs.	215 lbs.	310 lbs.	155 lbs.	255 lbs.	380 lbs.	170 lbs.	300 lbs.	450 lbs.
2-1/2"	165 lbs.	275 lbs.	410 lbs.	190 lbs.	320 lbs.	495 lbs.	215 lbs.	365 lbs.	575 lbs.
3-1/2"	200 lbs.	330 lbs.	485 lbs.	235 lbs.	405 lbs.	635 lbs.	260 lbs.	455 lbs.	730 lbs.
5-1/2"	N/A	N/A	N/A	315 lbs.	515 lbs.	735 lbs.	360 lbs.	610 lbs.	925 lbs.

Above listed values based on wood with a specific gravity of 0.35. Values for other woods can be obtained by multiplying above values by factors listed in Figure 1.

Figure 1

Specific Gravity of Wood	Multiplier
0.36 - 0.49	1.17
0.50 - 0.65	1.25
0.66 - 0.73	1.50



INSTRUCTIONS

Load: Parallel to Structural Member

Angles: G (30°), H (45°), and I (60°)

Material: Lag bolts in wood

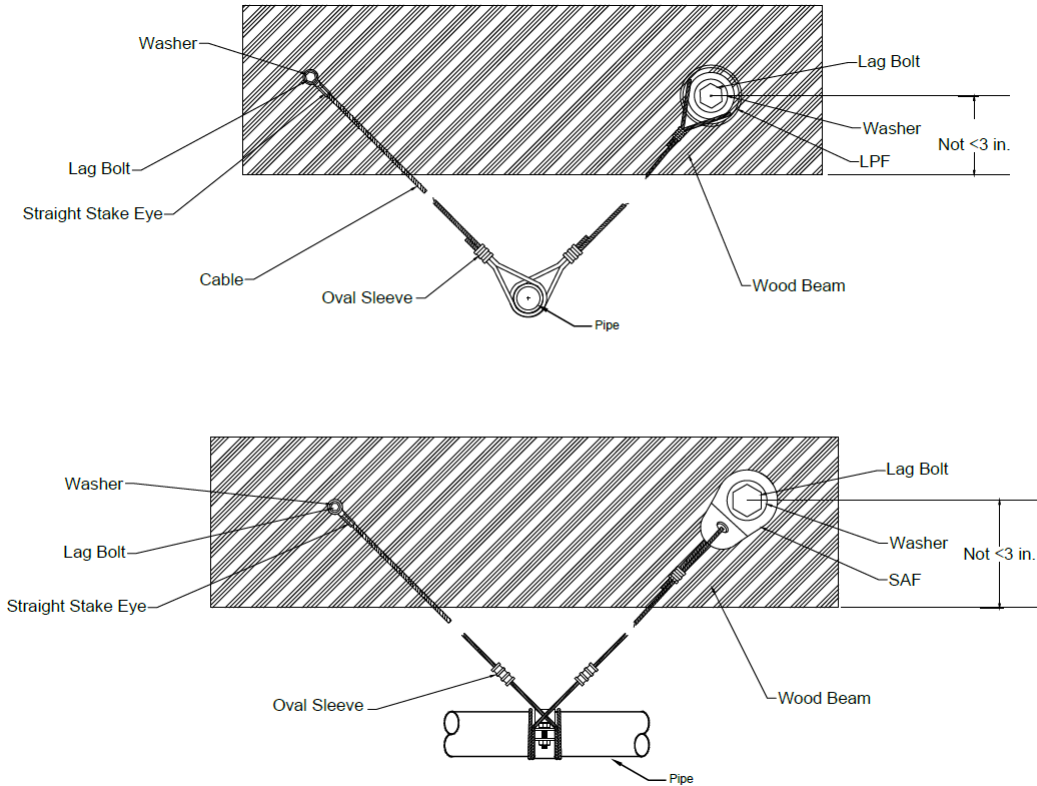

Lag Length	3/8" Lag Diameter			1/2" Lag Diameter			5/8" Lag Diameter		
	30° - 44°	45° - 59°	60° - 90°	30° - 44°	45° - 59°	60° - 90°	30° - 44°	45° - 59°	60° - 90°
3-1/2"	80 lbs.	120 lbs.	170 lbs.						
4-1/2"	80 lbs.	120 lbs.	170 lbs.	145 lbs.	230 lbs.	325 lbs.			
5-1/2"	80 lbs.	120 lbs.	170 lbs.	145 lbs.	230 lbs.	325 lbs.	195 lbs.	320 lbs.	460 lbs.
6-1/2"	80 lbs.	120 lbs.	170 lbs.	145 lbs.	230 lbs.	325 lbs.	195 lbs.	320 lbs.	460 lbs.

Above listed values based on wood with a specific gravity of 0.35. Values for other woods can be obtained by multiplying above values by factors listed in Figure 1.

Figure 1

Specific Gravity of Wood	Multiplier
0.36 - 0.49	1.17
0.50 - 0.65	1.25
0.66 - 0.73	1.50



Load: Parallel to Structural Member

Angles: G (30°), H (45°), and I (60°)

Material: Wedge anchors in 3,000 PSI normal-weight cracked concrete

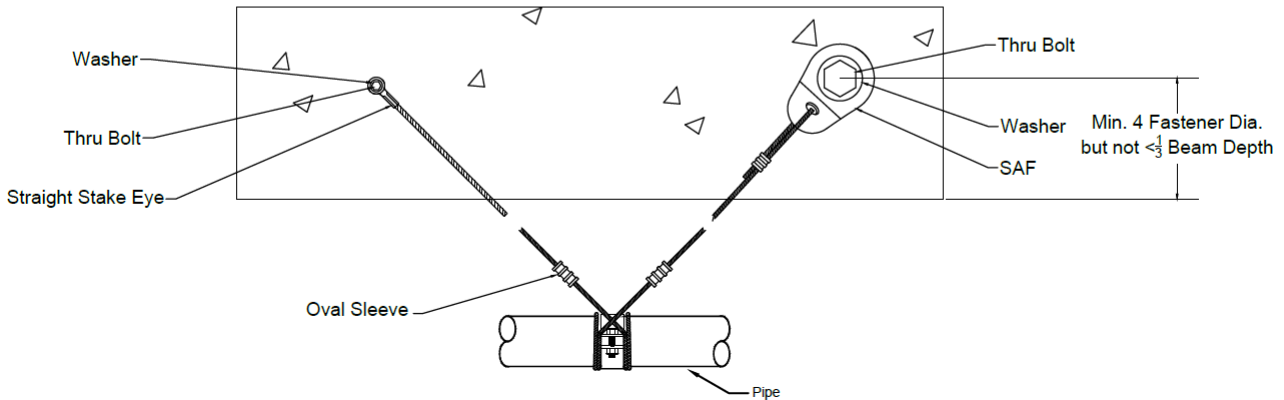
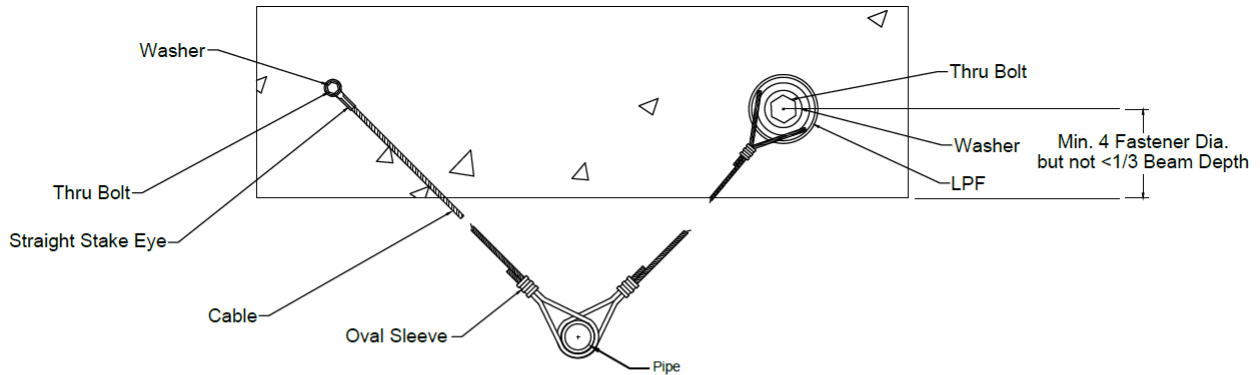

Maximum Load for Wedge Anchors in 3,000 psi (207 bar) Normal-Weight Cracked Concrete

Fastener Diameter	Fastener Embedment	LPF			SAF (All)			Stake Eye		
		30°-44°	45°-59°	60°-90°	30°-44°	45°-59°	60°-90°	30°-44°	45°-59°	60°-90°
3/8"	2"	145 lbs.	214 lbs.	254 lbs.	128 lbs.	184 lbs.	223 lbs.	128 lbs.	184 lbs.	223 lbs.
1/2"	3-5/8"	340 lbs.	498 lbs.	592 lbs.	302 lbs.	434 lbs.	523 lbs.	302 lbs.	434 lbs.	523 lbs.
5/8"	3-7/8"	479 lbs.	591 lbs.	703 lbs.	438 lbs.	512 lbs.	618 lbs.	N/A	N/A	N/A
3/4"	4-1/8"	482 lbs.	709 lbs.	839 lbs.	420 lbs.	604 lbs.	727 lbs.	N/A	N/A	N/A



INSTRUCTIONS

Load: Parallel to Structural Member

Angles: G (30°), H (45°), and I (60°)

Material: Undercut anchors in 3,000 PSI normal-weight cracked concrete

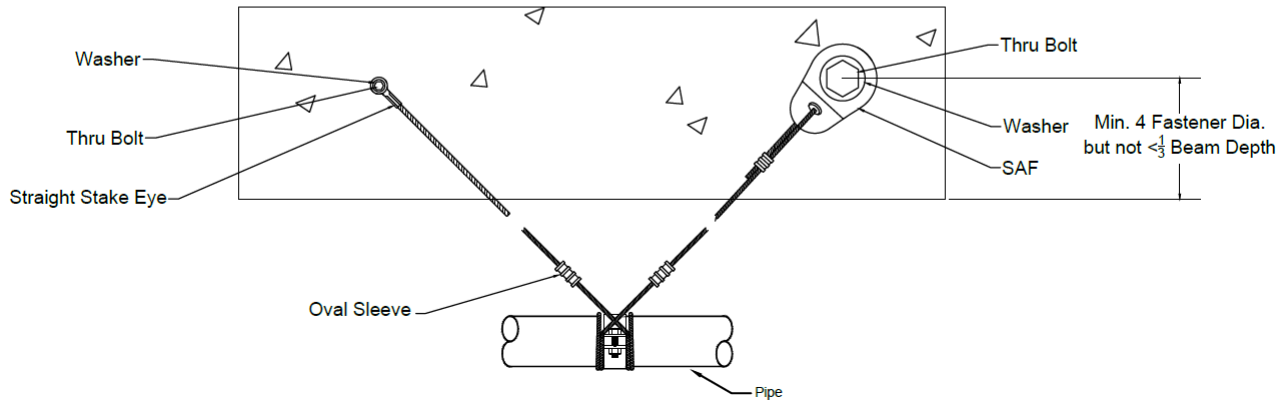
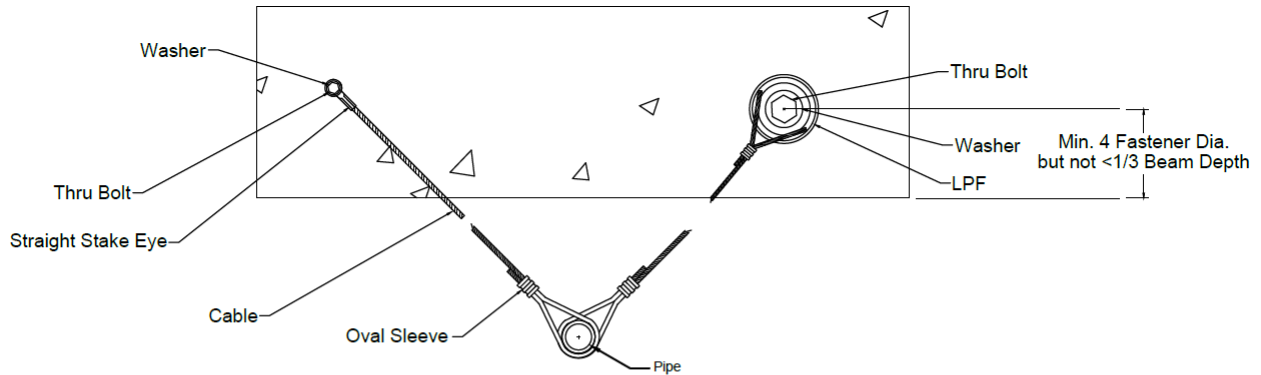

Maximum Load for Undercut Anchors in 3,000 psi (207 bar) Normal-Weight Cracked Concrete

Fastener Diameter	Fastener Embedment	LPF			SAF (All)			Stake Eye		
		30°-44°	45°-59°	60°-90°	30°-44°	45°-59°	60°-90°	30°-44°	45°-59°	60°-90°
3/8"	4-3/8"	362 lbs.	525 lbs.	630 lbs.	333 lbs.	477 lbs.	578 lbs.	333 lbs.	477 lbs.	578 lbs.
1/2"	7"	525 lbs.	761 lbs.	912 lbs.	479 lbs.	685 lbs.	829 lbs.	479 lbs.	685 lbs.	829 lbs.
5/8"	9-1/2"	1,098 lbs.	1,356 lbs.	1,612 lbs.	1,005 lbs.	1,177 lbs.	1,419 lbs.	N/A	N/A	N/A
3/4"	12"	1,472 lbs.	2,161 lbs.	2,561 lbs.	1,291 lbs.	1,854 lbs.	2,233 lbs.	N/A	N/A	N/A



Load: Parallel to Structural Member

Angles: G (30°), H (45°), and I (60°)

Material: Wedge anchors in 3,000 PSI lightweight cracked concrete

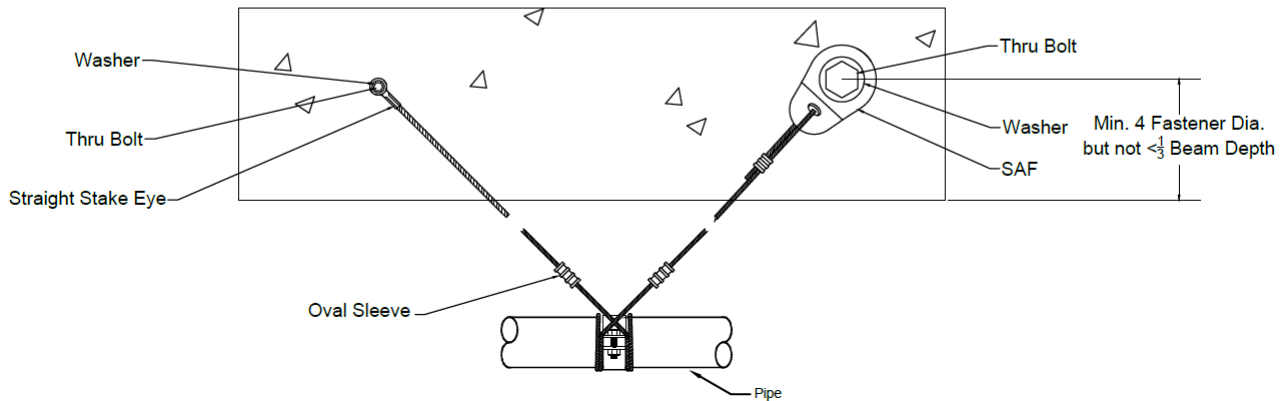
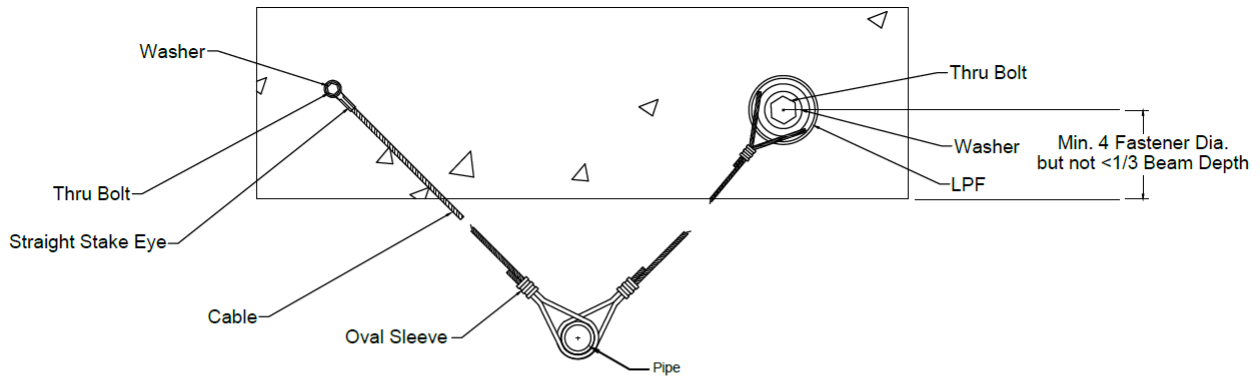

Maximum Load for Wedge Anchors in 3,000 psi (207 bar) Lightweight Cracked Concrete

Fastener Diameter	Fastener Embedment	LPF			SAF (All)			Stake Eye		
		30°-44°	45°-59°	60°-90°	30°-44°	45°-59°	60°-90°	30°-44°	45°-59°	60°-90°
3/8"	2"	87 lbs.	128 lbs.	152 lbs.	76 lbs.	110 lbs.	133 lbs.	76 lbs.	110 lbs.	133 lbs.
1/2"	2-3/8"	118 lbs.	174 lbs.	207 lbs.	104 lbs.	150 lbs.	181 lbs.	104 lbs.	150 lbs.	181 lbs.
5/8"	3-1/4"	220 lbs.	272 lbs.	323 lbs.	201 lbs.	237 lbs.	285 lbs.	N/A	N/A	N/A
3/4"	4-1/8"	289 lbs.	426 lbs.	504 lbs.	252 lbs.	362 lbs.	436 lbs.	N/A	N/A	N/A



INSTRUCTIONS

Load: Parallel to Structural Member

Angles: G (30°), H (45°), and I (60°)

Material: Wedge anchors in 4,000 PSI normal-weight cracked concrete

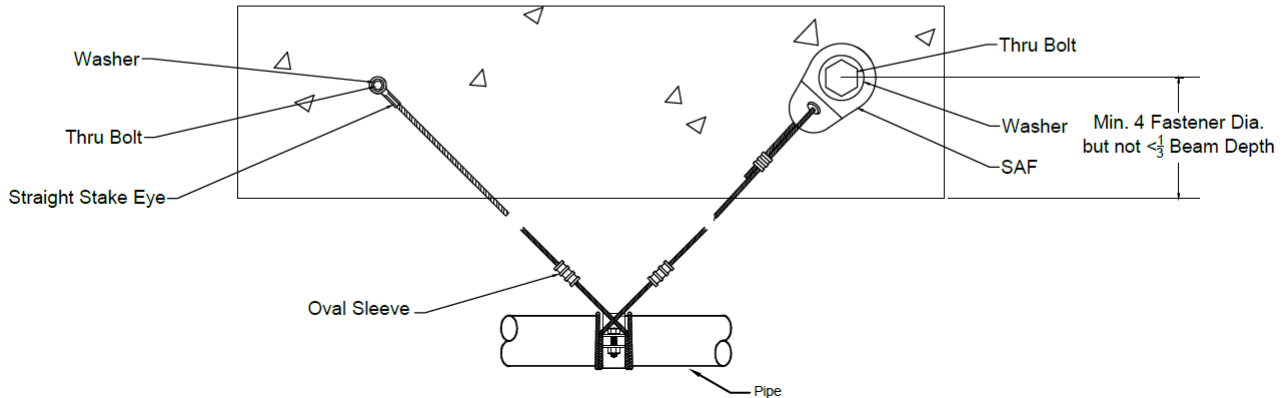
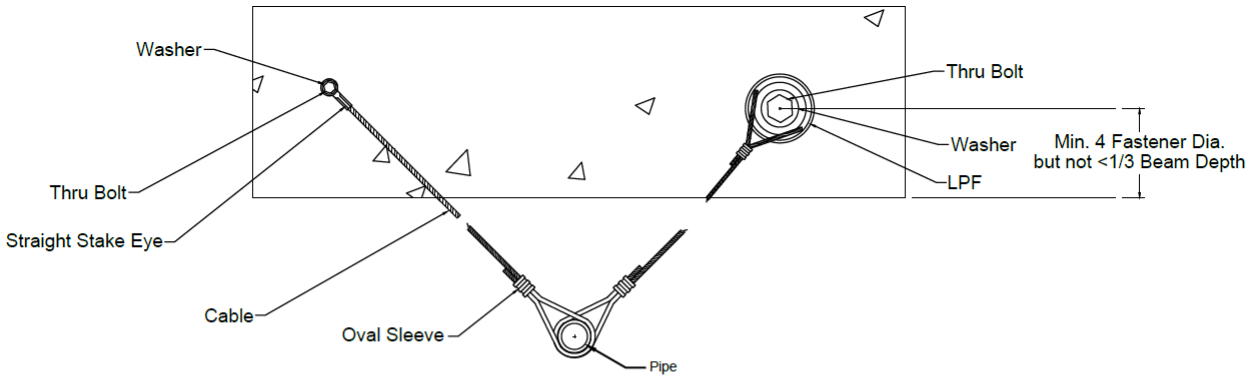

Maximum Load for Wedge Anchors in 4,000 psi (276 bar) Normal-Weight Cracked Concrete

Fastener Diameter	Fastener Embedment	LPF			SAF (All)			Stake Eye		
		30°-44°	45°-59°	60°-90°	30°-44°	45°-59°	60°-90°	30°-44°	45°-59°	60°-90°
3/8"	2"	171 lbs.	251 lbs.	299 lbs.	150 lbs.	216 lbs.	261 lbs.	150 lbs.	216 lbs.	261 lbs.
1/2"	3-5/8"	370 lbs.	544 lbs.	645 lbs.	325 lbs.	467 lbs.	563 lbs.	325 lbs.	467 lbs.	563 lbs.
5/8"	3-7/8"	511 lbs.	636 lbs.	758 lbs.	470 lbs.	557 lbs.	672 lbs.	N/A	N/A	N/A
3/4"	4-1/8"	558 lbs.	821 lbs.	971 lbs.	486 lbs.	699 lbs.	841 lbs.	N/A	N/A	N/A



Load: Parallel to Structural Member

Angles: G (30°), H (45°), and I (60°)

Material: Wedge anchors in 6,000 PSI normal-weight cracked concrete

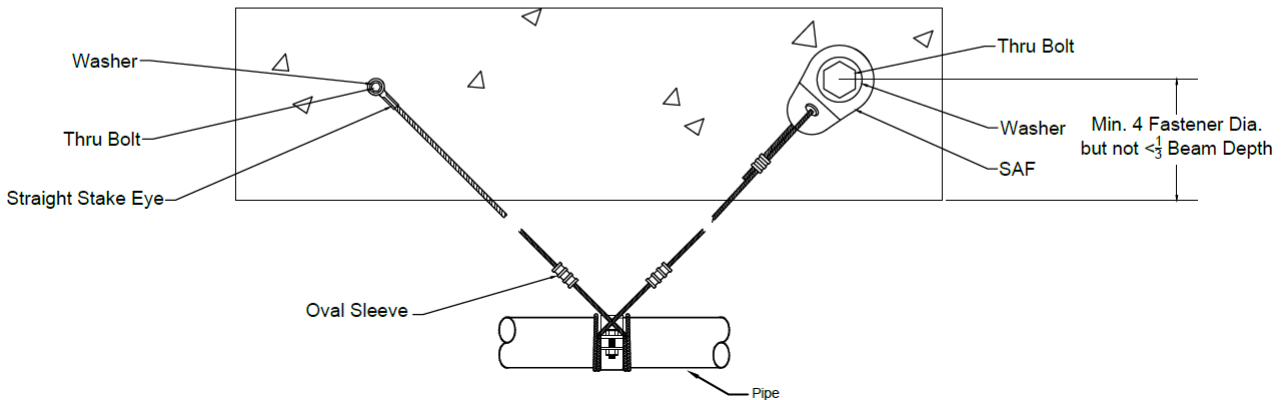
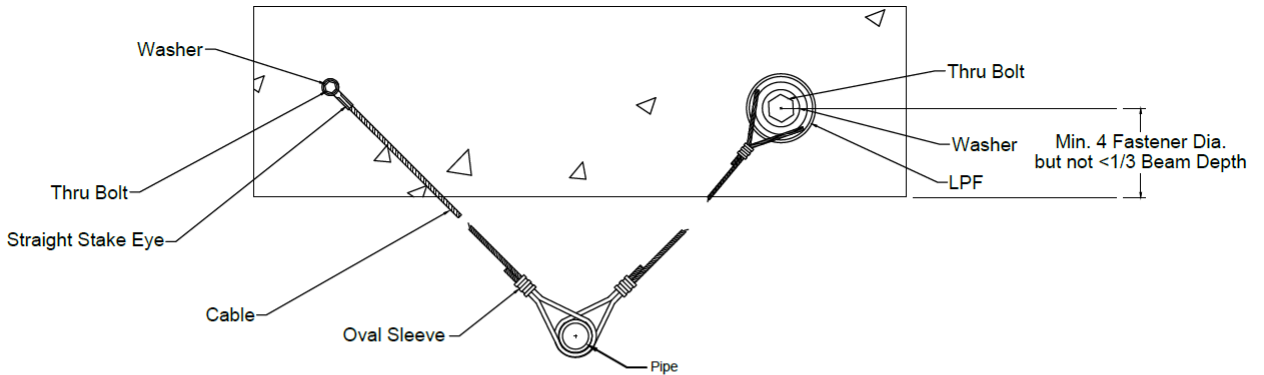

Maximum Load for Wedge Anchors in 6,000 psi (414 bar) Normal-Weight Cracked Concrete

Fastener Diameter	Fastener Embedment	LPF			SAF (All)			Stake Eye		
		30°-44°	45°-59°	60°-90°	30°-44°	45°-59°	60°-90°	30°-44°	45°-59°	60°-90°
3/8"	2-1/4"	213 lbs.	313 lbs.	372 lbs.	188 lbs.	271 lbs.	327 lbs.	188 lbs.	271 lbs.	327 lbs.
1/2"	3-5/8"	454 lbs.	667 lbs.	791 lbs.	399 lbs.	573 lbs.	690 lbs.	399 lbs.	573 lbs.	690 lbs.
5/8"	3-7/8"	626 lbs.	780 lbs.	928 lbs.	576 lbs.	682 lbs.	823 lbs.	N/A	N/A	N/A
3/4"	4-1/8"	684 lbs.	1,005 lbs.	1,190 lbs.	595 lbs.	856 lbs.	1,030 lbs.	N/A	N/A	N/A



INSTRUCTIONS

Load: Parallel to Structural Member

Angles: G (30°), H (45°), and I (60°)

Material: Connection to steel

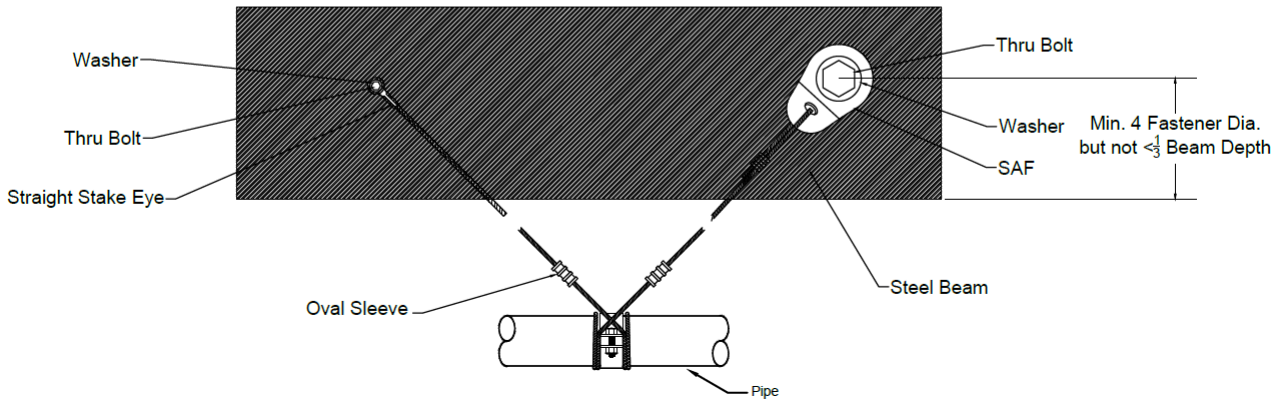
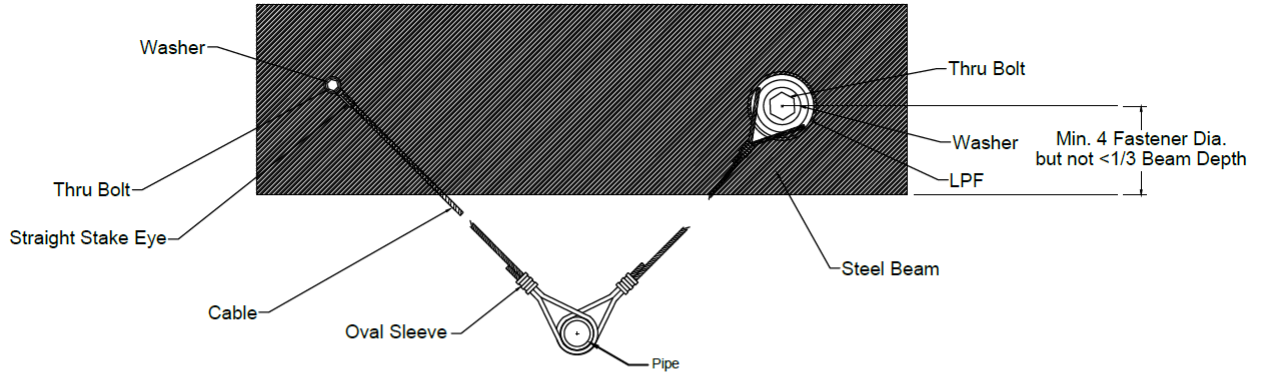

Diameter	30° - 44°	45° - 59°	60° - 90°
1/4"	325 lbs.	458 lbs.	565 lbs.
3/8"	735 lbs.	1,035 lbs.	1,278 lbs.
1/2"	1,300 lbs.	1,830 lbs.	2,260 lbs.
5/8"	2,045 lbs.	2,880 lbs.	3,557 lbs.



Load: Perpendicular to Structural Member

Angles: A (30°), B (45°), and C (60°)

Material: Cable looped around top member of bar joist

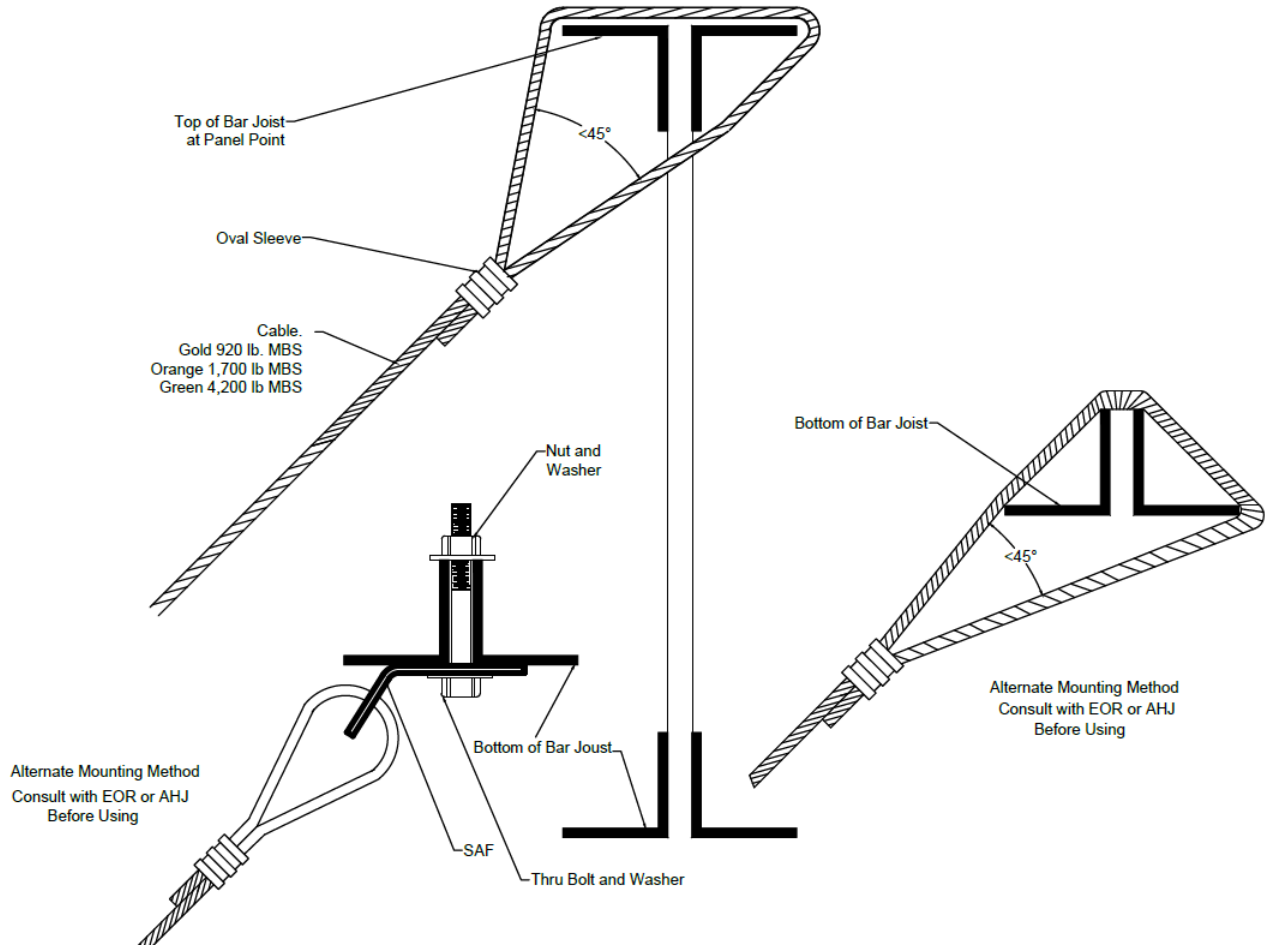

Cable Color	Working Load	30° - 44°	45° - 59°	60° - 90°
Gold	418 lbs.	209 lbs.	295 lbs.	361 lbs.
Orange	770 lbs.	385 lbs.	544 lbs.	666 lbs.
Green	1,900 lbs.	950 lbs.	1,343 lbs.	1,645 lbs.
Black	3,180 lbs.	1,590 lbs.	2,248 lbs.	2,753 lbs.



Typical Riser Bracing Angle Roof Installation

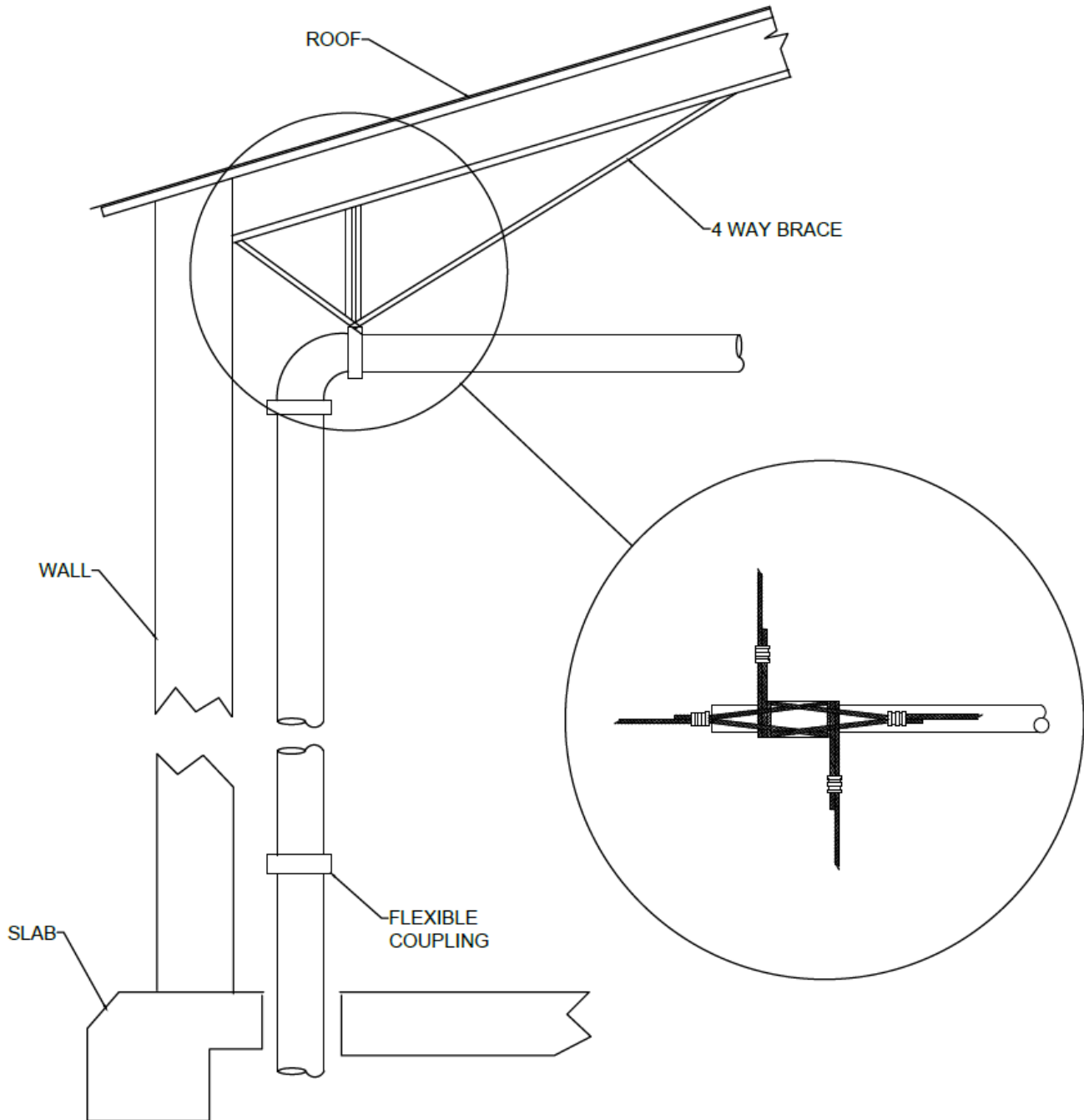

Typical Riser Bracing Flat Roof Installation

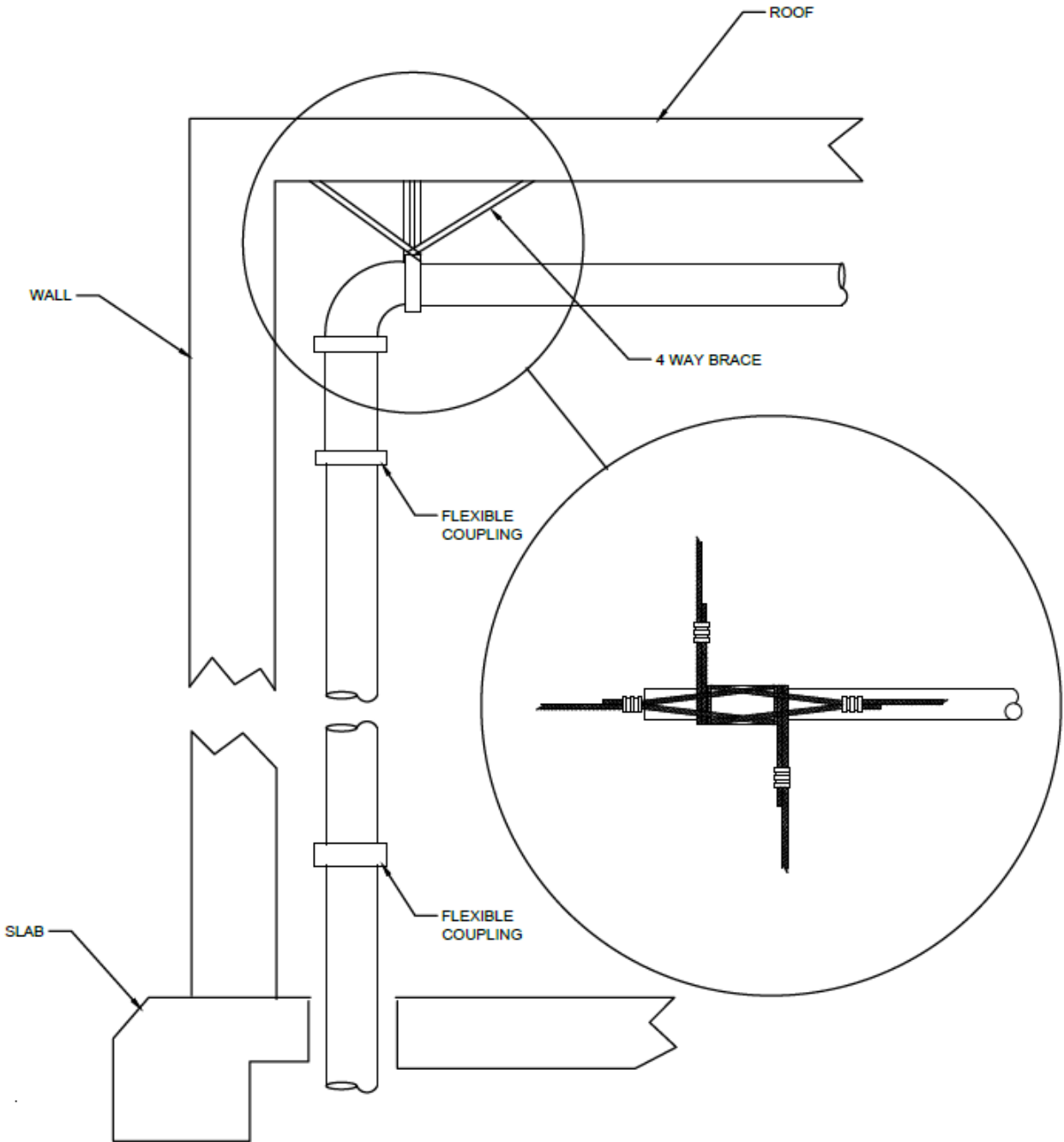

Typical Riser Bracing Wall Installation

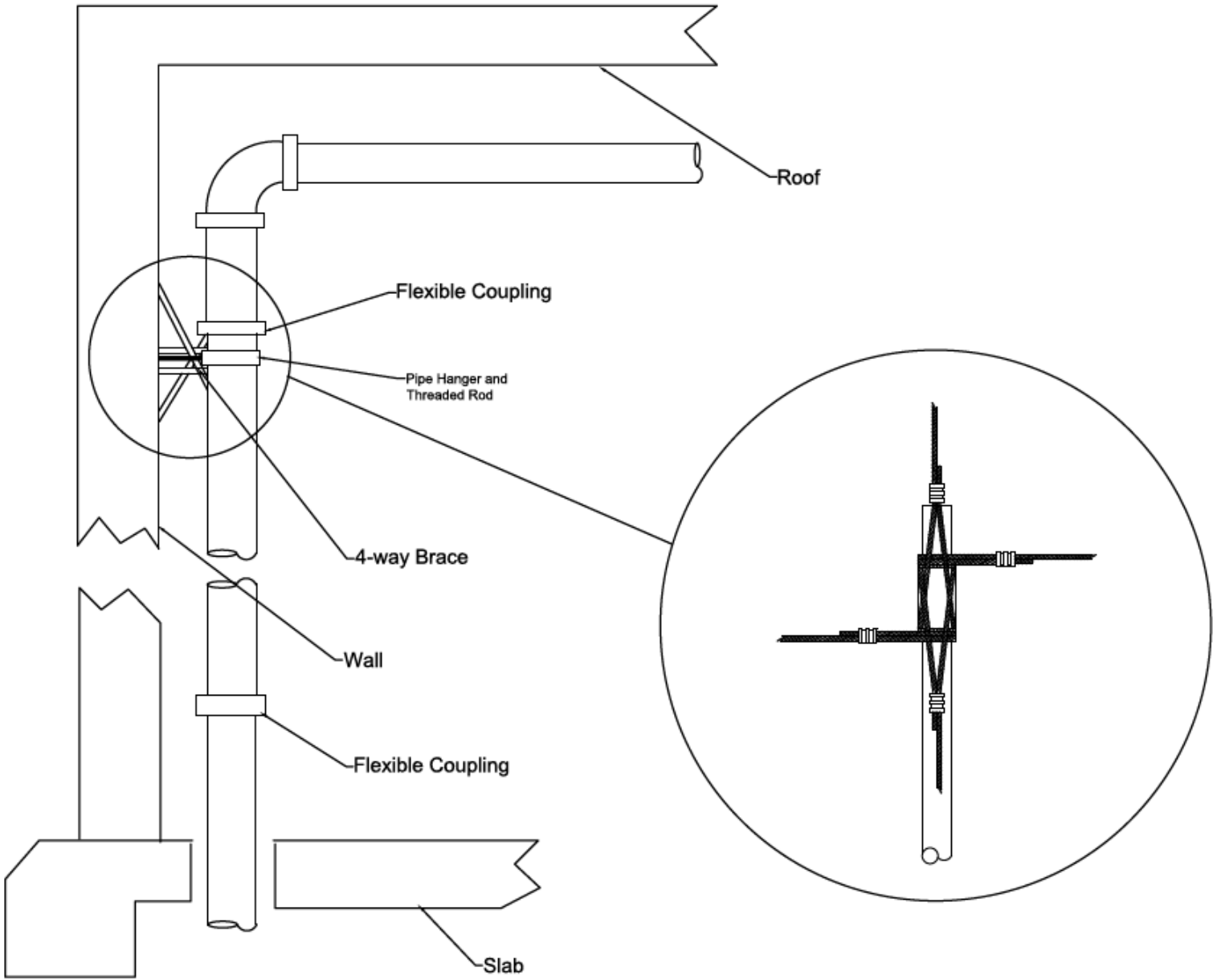

Clevis Hanger

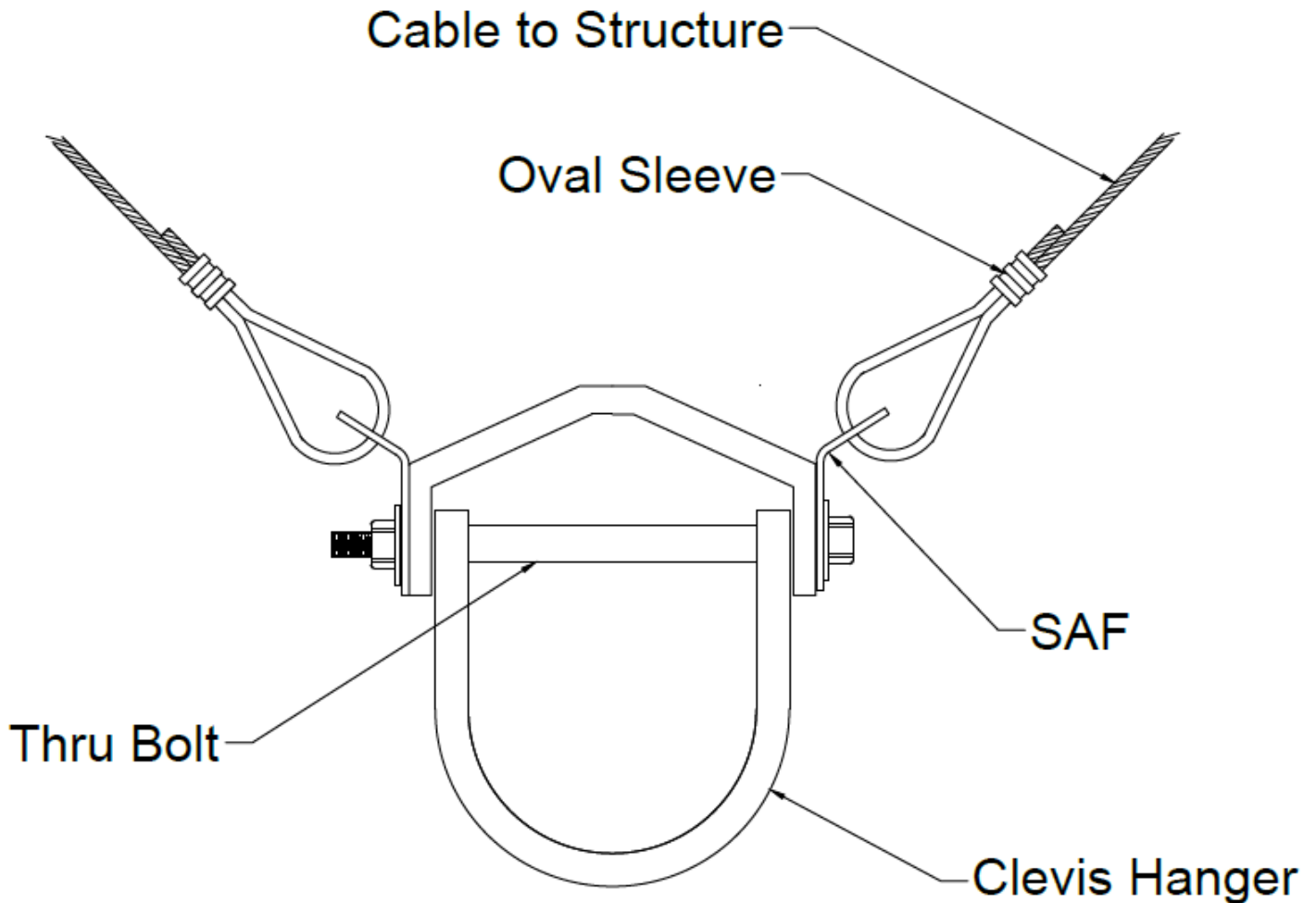

Lateral Bracing Option. Consult EOR or AHJ
before using



Pipe Hanger

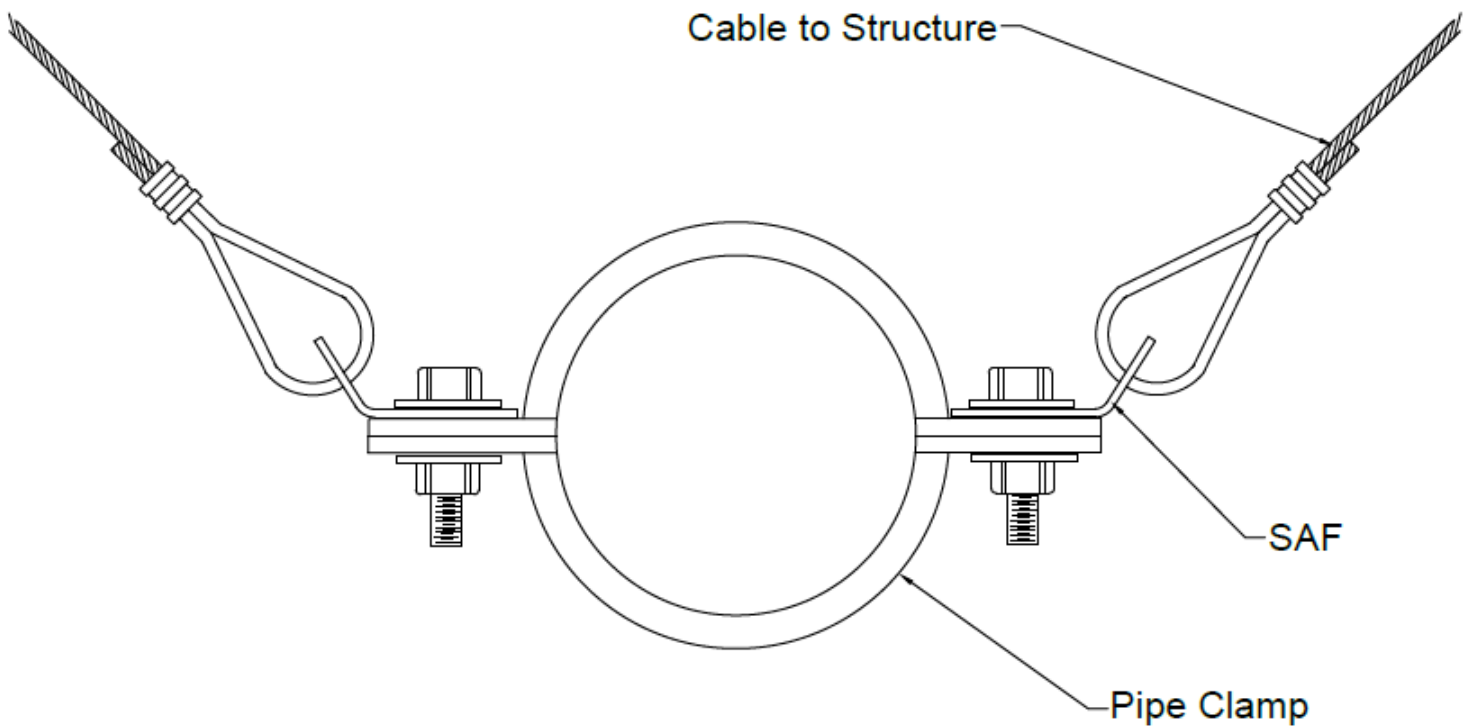

Lateral Bracing Option. Consult EOR or AHJ
before using



Appendix

Interpreting Maximum Horizontal Load Allowed on Weakest Components of Brace Assembly	
Brace Angle	Maximum Horizontal Load
30 to 44 Degrees from Vertical	Divide Listed Load Rating by 2,000
45 to 59 Degrees from Vertical	Divide Listed Load Rating by 1,414
60 to 89 Degrees from Vertical	Divide Listed Load Rating by 1,155
90 Degrees from Vertical	Use Listed Load Rated

The load applied to a bracing element, (the brace, fasteners, connectors and structure) are derived from standard calculations. The above table is part of those calculations. Example:

The Orange cable supplied by Loos & Co., Inc. has a certified minimum break strength of 1,700 pounds. The listed working load (load rating) is 1,700 pounds divided by a safety factor of 2.2, or 770 pounds.

Depending on the angle which is used in the installation, the listed working load (load rating) of 770 pounds is reduced again by the factor in the above table. That would allow an applied load of 770 pounds divided by 2 for a 30° installation angle, or 385 pounds.

Maximum Load for Wedge Anchors in 3000 psi (207 bar) Lightweight Cracked Concrete on Metal Deck											
			ORIENTATION 1			ORIENTATION 2			ORIENTATION 3		
PART	ANCHOR DIA.	DEPTH (in.)	30°	45°	60°	30°	45°	60°	30°	45°	60°
LPF-3/8	3/8"	2"	117	184	246	N/A	N/A	N/A	N/A	N/A	N/A
LPF-1/2	1/2"	2-3/8"	164	257	344	N/A	N/A	N/A	N/A	N/A	N/A
LPF-5/8	5/8"	3-1/8"	214	326	424	N/A	N/A	N/A	N/A	N/A	N/A

			ORIENTATION 1			ORIENTATION 2			ORIENTATION 3		
PART	ANCHOR DIA.	DEPTH (in.)	30°	45°	60°	30°	45°	60°	30°	45°	60°
SAF-3/8	3/8"	2"	69	127	196	N/A	N/A	N/A	N/A	N/A	N/A
SAF-1/2	1/2"	2-3/8"	97	178	274	N/A	N/A	N/A	N/A	N/A	N/A
SAF-5/8	5/8"	3-1/8"	133	232	346	N/A	N/A	N/A	N/A	N/A	N/A

			ORIENTATION 1			ORIENTATION 2			ORIENTATION 3		
PART	ANCHOR DIA.	DEPTH (in.)	30°	45°	60°	30°	45°	60°	30°	45°	60°
SAFR-3/8	3/8"	2"	69	127	196	N/A	N/A	N/A	N/A	N/A	N/A
SAFR-1/2	1/2"	2-3/8"	97	178	274	N/A	N/A	N/A	N/A	N/A	N/A
SAFR-5/8	5/8"	3-1/8"	133	232	346	N/A	N/A	N/A	N/A	N/A	N/A

			ORIENTATION 1			ORIENTATION 2			ORIENTATION 3		
PART	ANCHOR DIA.	DEPTH (in.)	30°	45°	60°	30°	45°	60°	30°	45°	60°
SAF2-3/8	3/8"	2"	69	127	196	N/A	N/A	N/A	N/A	N/A	N/A
SAF2-1/2	1/2"	2-3/8"	97	178	274	N/A	N/A	N/A	N/A	N/A	N/A
SAF2-5/8	5/8"	3-1/8"	133	232	346	N/A	N/A	N/A	N/A	N/A	N/A

			ORIENTATION 1			ORIENTATION 2			ORIENTATION 3		
PART	ANCHOR DIA.	DEPTH (in.)	30°	45°	60°	30°	45°	60°	30°	45°	60°
SAF2R-3/8	3/8"	2"	69	127	196	N/A	N/A	N/A	N/A	N/A	N/A
SAF2R-1/2	1/2"	2-3/8"	97	178	274	N/A	N/A	N/A	N/A	N/A	N/A
SAF2R-5/8	5/8"	3-1/8"	133	232	346	N/A	N/A	N/A	N/A	N/A	N/A

			ORIENTATION 1			ORIENTATION 2			ORIENTATION 3		
PART	ANCHOR DIA.	DEPTH (in.)	30°	45°	60°	30°	45°	60°	30°	45°	60°
GO-3B	3/8"	2"	69	127	N/A	N/A	N/A	N/A	N/A	N/A	N/A
OR-3B											
GR-3B											
OR-4B	1/2"	2-3/8"	97	178	N/A	N/A	N/A	N/A	N/A	N/A	N/A
GR-4B											

Maximum Load for Wedge Anchors in 3000 psi (207 bar) Lightweight Cracked Concrete											
			ORIENTATION 1			ORIENTATION 2			ORIENTATION 3		
PART	ANCHOR DIA.	DEPTH (in.)	30°	45°	60°	30°	45°	60°	30°	45°	60°
LPF-3/8	3/8"	2"	102	144	175	101	144	184	87	128	152
LPF-1/2	1/2"	2-3/8"	140	196	238	137	196	251	118	174	207
LPF-5/8	5/8"	3-1/8"	222	308	372	215	308	397	220	272	323
LPF-3/4	3/4"	4-1/8"	327	469	580	336	469	586	289	426	504
			ORIENTATION 1			ORIENTATION 2			ORIENTATION 3		
PART	ANCHOR DIA.	DEPTH (in.)	30°	45°	60°	30°	45°	60°	30°	45°	60°
SAF-3/8	3/8"	2"	69	109	150	87	109	121	76	110	133
SAF-1/2	1/2"	2-3/8"	94	149	205	119	149	166	104	150	181
SAF-5/8	5/8"	3-1/8"	151	237	322	187	237	265	201	236	285
SAF-3/4	3/4"	4-1/8"	217	351	492	286	351	380	252	362	436
			ORIENTATION 1			ORIENTATION 2			ORIENTATION 3		
PART	ANCHOR DIA.	DEPTH (in.)	30°	45°	60°	30°	45°	60°	30°	45°	60°
SAFR-3/8	3/8"	2"	69	109	150	87	109	121	76	110	133
SAFR-1/2	1/2"	2-3/8"	94	149	205	119	149	166	104	150	181
SAFR-5/8	5/8"	3-1/8"	151	237	322	187	237	265	201	236	285
			ORIENTATION 1			ORIENTATION 2			ORIENTATION 3		
PART	ANCHOR DIA.	DEPTH (in.)	30°	45°	60°	30°	45°	60°	30°	45°	60°
SAF2-3/8	3/8"	2"	69	109	150	87	109	121	76	110	133
SAF2-1/2	1/2"	2-3/8"	94	149	205	119	149	166	104	150	181
SAF2-5/8	5/8"	3-1/8"	151	237	322	187	237	265	201	236	285
SAF2-3/4	3/4"	4-1/8"	217	351	492	286	351	380	252	362	436
			ORIENTATION 1			ORIENTATION 2			ORIENTATION 3		
PART	ANCHOR DIA.	DEPTH (in.)	30°	45°	60°	30°	45°	60°	30°	45°	60°
SAF2R-3/8	3/8"	2"	69	109	150	87	109	121	76	110	133
SAF2R-1/2	1/2"	2-3/8"	94	149	205	119	149	166	104	150	181
SAF2R-5/8	5/8"	3-1/8"	151	237	322	187	237	265	201	236	285
			ORIENTATION 1			ORIENTATION 2			ORIENTATION 3		
PART	ANCHOR DIA.	DEPTH (in.)	30°	45°	60°	30°	45°	60°	30°	45°	60°
GO-3B	3/8"	2"	69	109	150	87	109	121	76	110	133
OR-3B											
GR-3B											
OR-4B	1/2"	2-3/8"	94	149	205	119	149	166	104	150	181
GR-4B											

Maximum Load for Wedge Anchors in 3000 psi (207 bar) Normal Weight Cracked Concrete											
			ORIENTATION 1			ORIENTATION 2			ORIENTATION 3		
PART	ANCHOR DIA.	DEPTH (in.)	30°	45°	60°	30°	45°	60°	30°	45°	60°
LPF-3/8	3/8"	2"	171	240	292	169	240	307	145	214	254
LPF-1/2	1/2"	2-3/8"	412	567	682	394	567	735	340	498	592
LPF-5/8	5/8"	3-1/8"	480	668	809	468	668	859	479	591	703
LPF-3/4	3/4"	4-1/8"	545	780	965	559	780	976	482	709	839
			ORIENTATION 1			ORIENTATION 2			ORIENTATION 3		
PART	ANCHOR DIA.	DEPTH (in.)	30°	45°	60°	30°	45°	60°	30°	45°	60°
SAF-3/8	3/8"	2"	116	183	252	146	183	203	128	184	223
SAF-1/2	1/2"	2-3/8"	282	438	592	344	438	493	302	434	523
SAF-5/8	5/8"	3-1/8"	327	512	699	406	512	571	438	512	618
SAF-3/4	3/4"	4-1/8"	363	584	819	477	584	634	420	604	727
			ORIENTATION 1			ORIENTATION 2			ORIENTATION 3		
PART	ANCHOR DIA.	DEPTH (in.)	30°	45°	60°	30°	45°	60°	30°	45°	60°
SAFR-3/8	3/8"	2"	116	183	252	146	183	203	128	184	223
SAFR-1/2	1/2"	2-3/8"	282	438	592	344	438	493	302	434	523
SAFR-5/8	5/8"	3-1/8"	327	512	699	406	512	571	438	512	618
			ORIENTATION 1			ORIENTATION 2			ORIENTATION 3		
PART	ANCHOR DIA.	DEPTH (in.)	30°	45°	60°	30°	45°	60°	30°	45°	60°
SAF2-3/8	3/8"	2"	116	183	252	146	183	203	128	184	223
SAF2-1/2	1/2"	2-3/8"	282	438	592	344	438	493	302	434	523
SAF2-5/8	5/8"	3-1/8"	327	512	699	406	512	571	438	512	618
SAF2-3/4	3/4"	4-1/8"	363	584	819	477	584	634	420	604	727
			ORIENTATION 1			ORIENTATION 2			ORIENTATION 3		
PART	ANCHOR DIA.	DEPTH (in.)	30°	45°	60°	30°	45°	60°	30°	45°	60°
SAF2R-3/8	3/8"	2"	116	183	252	146	183	203	128	184	223
SAF2R-1/2	1/2"	2-3/8"	282	438	592	344	438	493	302	434	523
SAF2R-5/8	5/8"	3-1/8"	327	512	699	406	512	571	438	512	618
			ORIENTATION 1			ORIENTATION 2			ORIENTATION 3		
PART	ANCHOR DIA.	DEPTH (in.)	30°	45°	60°	30°	45°	60°	30°	45°	60°
GO-3B	3/8"	2"	116	183	252	146	183	203	128	184	223
OR-3B											
GR-3B											
OR-4B	1/2"	2-3/8"	282	438	592	344	438	493	302	434	523
GR-4B											

Maximum Load for Undercut Anchors in 3000 psi (207 bar) Normal Weight Cracked Concrete											
			ORIENTATION 1			ORIENTATION 2			ORIENTATION 3		
PART	ANCHOR DIA.	DEPTH (in.)	30°	45°	60°	30°	45°	60°	30°	45°	60°
LPF-3/8	3/8"	2"	501	638	726	420	638	889	362	525	630
LPF-1/2	1/2"	2-3/8"	700	911	1051	608	911	1245	525	761	912
LPF-5/8	5/8"	3-1/8"	1106	1535	1855	1071	1535	1975	1098	1356	1612
LPF-3/4	3/4"	4-1/8"	1701	2404	2946	1707	2404	3041	1472	2161	2561
			ORIENTATION 1			ORIENTATION 2			ORIENTATION 3		
PART	ANCHOR DIA.	DEPTH (in.)	30°	45°	60°	30°	45°	60°	30°	45°	60°
SAF-3/8	3/8"	2"	368	526	658	381	526	643	333	477	578
SAF-1/2	1/2"	2-3/8"	505	738	942	547	738	882	479	685	829
SAF-5/8	5/8"	3-1/8"	754	1179	1604	933	1179	1318	1005	1177	1419
SAF-3/4	3/4"	4-1/8"	1143	1819	2520	1468	1819	1996	1291	1854	2233
			ORIENTATION 1			ORIENTATION 2			ORIENTATION 3		
PART	ANCHOR DIA.	DEPTH (in.)	30°	45°	60°	30°	45°	60°	30°	45°	60°
SAFR-3/8	3/8"	2"	368	526	658	381	526	643	333	477	578
SAFR-1/2	1/2"	2-3/8"	505	738	942	547	738	882	479	685	829
SAFR-5/8	5/8"	3-1/8"	754	1179	1604	933	1179	1318	1005	1177	1419
			ORIENTATION 1			ORIENTATION 2			ORIENTATION 3		
PART	ANCHOR DIA.	DEPTH (in.)	30°	45°	60°	30°	45°	60°	30°	45°	60°
SAF2-3/8	3/8"	2"	368	526	658	381	526	643	333	477	578
SAF2-1/2	1/2"	2-3/8"	505	738	942	547	738	882	479	685	829
SAF2-5/8	5/8"	3-1/8"	754	1179	1604	933	1179	1318	1005	1177	1419
SAF2-3/4	3/4"	4-1/8"	1143	1819	2520	1468	1819	1996	1291	1854	2233
			ORIENTATION 1			ORIENTATION 2			ORIENTATION 3		
PART	ANCHOR DIA.	DEPTH (in.)	30°	45°	60°	30°	45°	60°	30°	45°	60°
SAF2R-3/8	3/8"	2"	368	526	658	381	526	643	333	477	578
SAF2R-1/2	1/2"	2-3/8"	505	738	942	547	738	882	479	685	829
SAF2R-5/8	5/8"	3-1/8"	754	1179	1604	933	1179	1318	1005	1177	1419
			ORIENTATION 1			ORIENTATION 2			ORIENTATION 3		
PART	ANCHOR DIA.	DEPTH (in.)	30°	45°	60°	30°	45°	60°	30°	45°	60°
GO-3B	3/8"	2"	368	526	658	381	526	643	333	477	578
OR-3B											
GR-3B											
OR-4B	1/2"	2-3/8"	505	738	942	547	738	882	479	685	829
GR-4B											

Maximum Load for Wedge Anchors in 4000 psi (276 bar) Normal Weight Cracked Concrete											
			ORIENTATION 1			ORIENTATION 2			ORIENTATION 3		
PART	ANCHOR DIA.	DEPTH (in.)	30°	45°	60°	30°	45°	60°	30°	45°	60°
LPF-3/8	3/8"	2"	200	282	344	199	282	359	171	251	299
LPF-1/2	1/2"	2-3/8"	430	607	742	430	607	770	370	544	645
LPF-5/8	5/8"	3-1/8"	532	729	872	505	729	950	511	636	758
LPF-3/4	3/4"	4-1/8"	630	903	1117	647	903	1129	558	821	971
			ORIENTATION 1			ORIENTATION 2			ORIENTATION 3		
PART	ANCHOR DIA.	DEPTH (in.)	30°	45°	60°	30°	45°	60°	30°	45°	60°
SAF-3/8	3/8"	2"	135	214	295	171	214	236	150	216	261
SAF-1/2	1/2"	2-3/8"	289	460	636	370	460	506	325	467	563
SAF-5/8	5/8"	3-1/8"	367	566	760	442	566	642	470	557	672
SAF-3/4	3/4"	4-1/8"	419	676	948	552	676	733	486	699	841
			ORIENTATION 1			ORIENTATION 2			ORIENTATION 3		
PART	ANCHOR DIA.	DEPTH (in.)	30°	45°	60°	30°	45°	60°	30°	45°	60°
SAFR-3/8	3/8"	2"	135	214	295	171	214	236	150	216	261
SAFR-1/2	1/2"	2-3/8"	289	460	636	370	460	506	325	467	563
SAFR-5/8	5/8"	3-1/8"	367	566	760	442	566	642	470	557	672
			ORIENTATION 1			ORIENTATION 2			ORIENTATION 3		
PART	ANCHOR DIA.	DEPTH (in.)	30°	45°	60°	30°	45°	60°	30°	45°	60°
SAF2-3/8	3/8"	2"	135	214	295	171	214	236	150	216	261
SAF2-1/2	1/2"	2-3/8"	289	460	636	370	460	506	325	467	563
SAF2-5/8	5/8"	3-1/8"	367	566	760	442	566	642	470	557	672
SAF2-3/4	3/4"	4-1/8"	419	676	948	552	676	733	486	699	841
			ORIENTATION 1			ORIENTATION 2			ORIENTATION 3		
PART	ANCHOR DIA.	DEPTH (in.)	30°	45°	60°	30°	45°	60°	30°	45°	60°
SAF2R-3/8	3/8"	2"	135	214	295	171	214	236	150	216	261
SAF2R-1/2	1/2"	2-3/8"	289	460	636	370	460	506	325	467	563
SAF2R-5/8	5/8"	3-1/8"	367	566	760	442	566	642	470	557	672
			ORIENTATION 1			ORIENTATION 2			ORIENTATION 3		
PART	ANCHOR DIA.	DEPTH (in.)	30°	45°	60°	30°	45°	60°	30°	45°	60°
GO-3B	3/8"	2"	135	214	295	171	214	236	150	216	261
OR-3B											
GR-3B											
OR-4B	1/2"	2-3/8"	289	460	636	370	460	506	325	467	563
GR-4B											

Maximum Load for Wedge Anchors in 6000 psi (414 bar) Normal Weight Cracked Concrete											
			ORIENTATION 1			ORIENTATION 2			ORIENTATION 3		
PART	ANCHOR DIA.	DEPTH (in.)	30°	45°	60°	30°	45°	60°	30°	45°	60°
LPF-3/8	3/8"	2"	254	354	428	199	354	585	213	313	372
LPF-1/2	1/2"	2-3/8"	527	744	910	418	744	1227	454	667	791
LPF-5/8	5/8"	3-1/8"	652	893	1069	504	893	1481	626	780	928
LPF-3/4	3/4"	4-1/8"	772	1106	1369	622	1106	1816	684	1005	1190
			ORIENTATION 1			ORIENTATION 2			ORIENTATION 3		
PART	ANCHOR DIA.	DEPTH (in.)	30°	45°	60°	30°	45°	60°	30°	45°	60°
SAF-3/8	3/8"	2"	172	271	370	215	271	302	188	271	327
SAF-1/2	1/2"	2-3/8"	355	564	780	453	564	621	399	573	690
SAF-5/8	5/8"	3-1/8"	450	694	932	542	694	786	576	682	823
SAF-3/4	3/4"	4-1/8"	514	828	1162	676	828	898	595	856	1030
			ORIENTATION 1			ORIENTATION 2			ORIENTATION 3		
PART	ANCHOR DIA.	DEPTH (in.)	30°	45°	60°	30°	45°	60°	30°	45°	60°
SAFR-3/8	3/8"	2"	172	271	370	215	271	302	188	271	327
SAFR-1/2	1/2"	2-3/8"	355	564	780	453	564	621	399	573	690
SAFR-5/8	5/8"	3-1/8"	450	694	932	542	694	786	576	682	823
			ORIENTATION 1			ORIENTATION 2			ORIENTATION 3		
PART	ANCHOR DIA.	DEPTH (in.)	30°	45°	60°	30°	45°	60°	30°	45°	60°
SAF2-3/8	3/8"	2"	172	271	370	215	271	302	188	271	327
SAF2-1/2	1/2"	2-3/8"	355	564	780	453	564	621	399	573	690
SAF2-5/8	5/8"	3-1/8"	450	694	932	542	694	786	576	682	823
SAF2-3/4	3/4"	4-1/8"	514	828	1162	676	828	898	595	856	1030
			ORIENTATION 1			ORIENTATION 2			ORIENTATION 3		
PART	ANCHOR DIA.	DEPTH (in.)	30°	45°	60°	30°	45°	60°	30°	45°	60°
SAF2R-3/8	3/8"	2"	172	271	370	215	271	302	188	271	327
SAF2R-1/2	1/2"	2-3/8"	355	564	780	453	564	621	399	573	690
SAF2R-5/8	5/8"	3-1/8"	450	694	932	542	694	786	576	682	823
			ORIENTATION 1			ORIENTATION 2			ORIENTATION 3		
PART	ANCHOR DIA.	DEPTH (in.)	30°	45°	60°	30°	45°	60°	30°	45°	60°
GO-3B	3/8"	2"	172	271	370	215	271	302	188	271	327
OR-3B											
GR-3B											
OR-4B	1/2"	2-3/8"	355	564	780	453	564	621	399	573	690
GR-4B											

Piping Weights for Determining Horizontal Load	
Nominal Dimension	Weight of Water Filled Pipe

CPVC Pipe	
in.	lbs/ft
¾	0.44
1	0.67
1 ¼	1.08
1 ½	1.41
2	2.20
2 ½	3.26
3	4.83

Diameter of Piping in Inches	Total Length of Piping in ft.								
	1	5	10	15	20	25	30	35	40
¾	0.44	2.20	4.40	6.60	8.80	11.00	13.20	15.40	17.60
1	0.67	3.35	6.70	10.05	13.40	16.75	20.10	23.45	26.80
1 ¼	1.08	5.40	10.80	16.20	21.60	27.00	32.40	37.80	43.20
1 ½	1.41	7.05	14.10	21.15	28.20	35.25	42.30	49.35	56.40
2	2.20	11.00	22.00	33.00	44.00	55.00	66.00	77.00	88.00
2 ½	3.26	16.30	32.60	48.90	65.20	81.50	97.80	114.10	130.40
3	4.83	24.15	48.30	72.45	96.60	120.75	144.90	169.05	193.20

SCHEDULE 7 PIPE WEIGHTS

Piping Weights for Determining Horizontal Load	
Nominal Dimension	Weight of Water Filled Pipe

Schedule 7 Pipe	
in.	lbs/ft
1 ¼	1.904
1 ½	2.586
2	3.631
2 ½	4.998
3	7.090
4	10.669
6	21.900

Diameter of Piping in Inches	Total Length of Piping in ft.								
	1	5	10	15	20	25	30	35	40
1 ¼	1.904	9.52	19.04	28.56	38.08	47.60	57.12	66.61	76.16
1 ½	2.586	12.93	25.86	38.79	51.72	64.65	77.58	90.51	103.44
2	3.631	18.16	36.31	54.47	72.62	90.78	108.93	127.09	145.24
2 ½	4.998	24.99	49.98	74.97	99.96	124.95	149.94	174.93	199.92
3	7.090	35.45	70.90	106.35	141.80	177.25	212.70	248.15	283.60
4	10.669	53.35	106.69	160.04	213.38	266.73	320.07	373.42	426.76
6	21.900	109.50	219.00	328.50	438.00	547.50	657.00	766.50	876.00

SCHEDULE 10 PIPE WEIGHTS

Piping Weights for Determining Horizontal Load	
Nominal Dimensions	Weight of Water-Filled Pipe

Schedule 10 Pipe	
in.	lb/ft
1	1.81
1¼	2.52
1½	3.04
2	4.22
2½	5.89
3	7.94
3½	9.78
4	11.78
5	17.3
6	23.03
8	40.08

Diameter of Piping in Inches	Total Length of Piping in ft								
	1	5	10	15	20	25	30	35	40
1	1.81	9.05	18.1	27.15	36.2	45.25	54.3	63.35	72.4
1¼	2.52	12.6	25.2	37.8	50.4	63	75.6	88.2	100.8
1½	3.04	15.2	30.4	45.6	60.8	76	91.2	106.4	121.6
2	4.22	21.1	42.2	63.3	84.4	105.5	126.6	147.7	168.8
2½	5.89	29.45	58.9	88.35	117.8	147.25	176.7	206.15	235.6
3	7.94	39.7	79.4	119.1	158.8	198.5	238.2	277.9	317.6
3½	9.78	48.9	97.8	146.7	195.6	244.5	293.4	342.3	391.2
4	11.78	58.9	117.8	176.7	235.6	294.5	353.4	412.3	471.2
5	17.3	86.5	173	259.5	346	432.5	519	605.5	692
6	23.03	115.15	230.3	345.45	460.6	575.75	690.9	806.05	921.2
8	40.08	200.4	400.8	601.2	801.6	1002	1202.4	1402.8	1603.2

SCHEDULE 40 PIPE WEIGHTS

Piping Weights for Determining Horizontal Load	
Nominal Dimensions	Weight of Water-Filled Pipe

Schedule 40 Pipe	
in.	lb/ft
1	2.05
1¼	2.93
1½	3.61
2	5.13
2½	7.89
3	10.82
3½	13.48
4	16.4
5	23.47
6	31.69
8	47.7

Diameter of Piping in Inches	Total Length of Piping in ft								
	1	5	10	15	20	25	30	35	40
1	2.05	10.25	20.5	30.75	41	51.25	61.5	71.75	82
1¼	2.93	14.65	29.3	43.95	58.6	73.25	87.9	102.55	117.2
1½	3.61	18.05	36.1	54.15	72.2	90.25	108.3	126.35	144.4
2	5.13	25.65	51.3	76.95	102.6	128.25	153.9	179.55	205.2
2½	7.89	39.45	78.9	118.35	157.8	197.25	236.7	276.15	315.6
3	10.82	54.1	108.2	162.3	216.4	270.5	324.6	378.7	432.8
3½	13.48	67.4	134.8	202.2	269.6	337	404.4	471.8	539.2
4	16.4	82	164	246	328	410	492	574	656
5	23.47	117.35	234.7	352.05	469.4	586.75	704.1	821.45	938.8
6	31.69	158.45	316.9	475.35	633.8	792.25	950.7	1109.15	1267.6
8	47.7	238.5	477	715.5	954	1192.5	1431	1669.5	1908

Concrete Anchor Orientations & Respective Prying Factor Formula

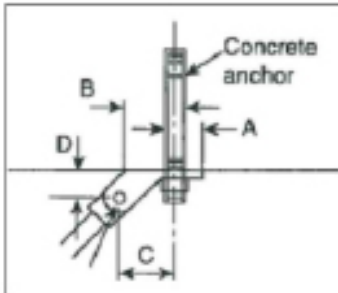

$$Pr = \frac{\left(\frac{C + A}{\tan\theta}\right) - D}{A}$$

Orientation 1, Angles "A", "B", and "C".

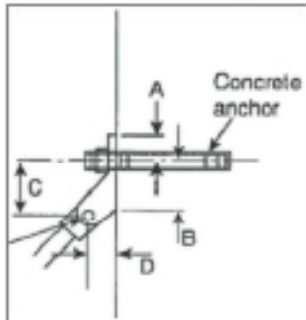

$$Pr = \frac{(C + A) - \left(\frac{D}{\tan\theta}\right)}{A}$$

Orientation 2, Angles "D", "E", and "F".

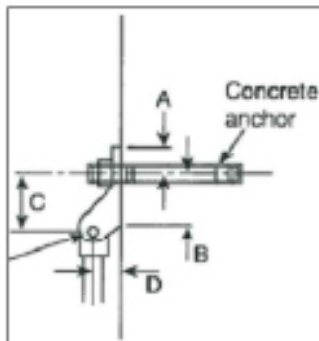

$$Pr = \frac{\left(\frac{D}{B}\right)}{\sin\theta}$$

Orientation 3, Angles "G", "H", and "I".

	30°	45°	60°
Sin	0.5	0.7071	0.866
Tan	0.5773	1	1.732

SEISMIC COEFFICIENT TABLE

Seismic Coefficient Table				
S_s	C_p		S_s	C_p
0.33 or Less	0.35		1.7	0.79
0.4	0.38		1.75	0.82
0.45	0.39		1.8	0.84
0.5	0.4		1.85	0.865
0.55	0.41		1.9	0.89
0.6	0.42		1.95	0.91
0.65	0.42		2	0.93
0.7	0.42		2.05	0.955
0.75	0.42		2.1	0.98
0.8	0.44		2.15	1.005
0.85	0.46		2.2	1.03
0.9	0.48		2.25	1.05
0.95	0.5		2.3	1.07
1	0.51		2.35	1.095
1.05	0.525		2.4	1.12
1.1	0.54		2.45	1.145
1.15	0.555		2.5	1.17
1.2	0.57		2.55	1.19
1.25	0.58		2.6	1.21
1.3	0.61		2.65	1.235
1.35	0.63		2.7	1.26
1.4	0.65		2.75	1.285
1.45	0.675		2.8	1.31
1.5	0.7		2.85	1.33
1.55	0.725		2.9	1.35
1.6	0.75		2.95	1.375
1.65	0.77		3	1.4

Data Derived from NFPA-13 2010

The below formula was used to calculate the table above.

$$C_p = C_{p-low} + \frac{C_{p-high} - C_{p-low}}{S_{s-high} - S_{s-low}} (S_s - S_{s-low})$$

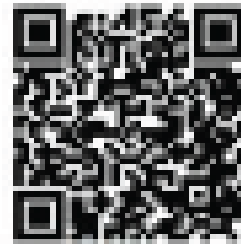

How-To Video Series



Seismic Calculator

901 INDUSTRIAL BLVD.
NAPLES, FL 34104
800.321.LOOS (5667)
LOOSSEISMICBRACING.COM